THE HENDERSHOT MYSTERY

**Printed, published and distributed by
NUTECH 2000**

**VICTORIA
AUSTRALIA
TELEPHONE: (03) 9457 2814**



All rights reserved
No part of this book may be reproduced
for the purpose of sale or distribution
without the Author's written permission

©
1998



SECRETS OF PERPETUAL POWER

First Published July 1998

This book is dedicated to all those battlers who dream that their persistent expenditure and efforts in experimentation may someday, somewhere, eventually make a difference.

TABLE OF CONTENT		PAGE
CHAPTER 1		3
POWER AND PREJUDICE		
CHAPTER 2		8
THE HENDERSHOT "FUELLESS" MOTOR		
CHAPTER 3		17
HENDERSHOT'S SOLID STATE GENERATOR		
CHAPTER 4		34
HENDERSHOT'S MARK II SOLID STATE GENERATOR		
CHAPTER 5		41
THE MARK III HENDERSHOT DEVICE		
CHAPTER 6		68
THE HENDERSHOT ENIGMA		
APPENDICES		
APPENDIX A		1-15
HENDERSHOT NEWSPAPER TRANSCRIPTS		
APPENDIX B		1-17
BOOK REFERENCES & MAGAZINE ARTICLES		
APPENDIX C		1-11
LESTER HENDERSHOT STORY BY MARK HENDERSHOT		
APPENDIX D		1-11
THE HENDERSHOT PATENT DRAFT		
APPENDIX E		1-3
PRINCIPLE OF EARTH INDUCTOR COMPASS		

POWER AND PREJUDICE

During the period 1925 to 1928, an unknown backyard inventor by the name of Lester Hendershot, who lived in Elizabeth, a small town near Pittsburgh USA, constructed a device that could be utilised either as a motor or to supply electricity without the use of any known conventional fuel.

That his invention worked, and was not the outlandish claim of some fraudulent individual or crackpot, has been fully documented in the appendices to this book. Hendershot had been educated to high school level and had only the most basic understanding of conventional electrical theory, yet working entirely on his own and financed from his own meagre income, he produced what should have been acclaimed as the most revolutionary invention of the twentieth century. But like so many other inventors, whose creations have threatened the power base of big business, his efforts to achieve commercial success were to prove fruitless.

In the fall of 1927, Hendershot had perfected his inventions to the point where they could be effectively demonstrated to potential financiers. In this pursuit, he enlisted the help of a gentleman by the name of D. Barr Peat, the Manager of the local airfield, who had become so enthusiastic in Hendershot's work, that he immediately made arrangements for further demonstrations to influential officials he considered could assist in its commercial exploitation. The potential magnitude of Hendershot's discoveries was so great, that it was soon snapped up by the American press, and Hendershot became a national celebrity overnight. Realising the possible impact that such an invention could have on the US economy, the wealthy industrialists, who controlled the power and fossil fuel markets, were quick to act, and within just a few days the entire incident was buried in the archives of the American press.

Within those few days of National prominence, Hendershot was to suffer a debilitating injury from an electric shock, threats to his life and humiliation in an attempt to brand him as a fraud. Finally, he was to be silenced by the powerful vested interests who wished to retain the status quo.

Unfortunately, history will never know whether Hendershot's injury was accidental or deliberate nor the true facts that so effectively prevented him from developing his devices for commercial use. It is however reasonably certain that Hendershot was frightened off by threats and paid off (according to his son - for an amount of \$25,000) to prevent further public disclosure. The patent application drafted by a patent attorney for a solid state generator, was likewise quashed to prevent any details of the device's construction becoming public knowledge. Any further mention of his achievements in the press were conspicuous by their absence (with the exception of one small article in November of 1928).

As J. P. Morgan put it in 1901, when denying Tesla funds to continue his development of transmitted free electricity, "If I can't put a meter on it - then we won't back it." Accordingly, neither of Hendershot's two principle inventions - "The Fuelless Motor", nor "The Free Energy solid state Generator", have ever found their way into commercial use. Furthermore, it is most unlikely that they ever will, unless some other enterprising inventor rediscovers the secret and obtains the commercial backing to develop and market it.

My purpose here is to combine all that is known about Lester Hendershot and his inventions in a comprehensive and clearly presented form. Thus, those interested in this line of research may be able to rediscover and publish what Lester Hendershot failed to pass on to the rest of humanity.

It is understood, that at the time of his death in 1961, at the age of 62 and confined to a wheelchair, he was prepared to reveal all for posterity. But before this revelation could take place, he passed away suddenly, from what was claimed to be suicide.

It is to Mark Hendershot, the youngest of Lester Hendershot's three sons, that we are indebted for making public some of the documents of his father's that came into his possession. It is Mark Hendershot's wish that his father not be forgotten and that others may do the research to rediscover the mysteries of his father's work.

It is in this spirit that I have tried to recreate and interpret the details of Lester Hendershot's designs and apparatus and provide the focus for retracing the steps taken by him, and from this knowledge, to move forward into uncharted territories.

For those who need convincing that Lester Hendershot's discoveries were genuine and really did work, or wish to know the full recorded history of the Hendershot saga, I have included all the newspaper reports and articles that I could find on the matter at Appendices A & B. I have also included an account of Lester Hendershot's history as told by his son, Mark Hendershot at Appendix C.

In scientific terms, the Lester Hendershot discoveries, violated the first law of physics, "You can't get something for nothing". This belief originated with René Descartes (1596-1650) in his books, "Principia Philosophiae" published in 1644, and again plagiaristically reiterated by Sir Isaac Newton (1642-1727) in the "Philosophiae Naturaliae Principia Mathematica",* in 1686. The development of Thermodynamics derived from Lazare Nicolas Carnot's (1753-1823) work, also applied this principle. Thus, the idea that one could generate electricity or drive a motor without any apparent fuel source, was totally unacceptable to the accredited scientific establishment of the day. Even today, some seventy years after Hendershot had demonstrated his devices, the official view of the scientific community is, that it can't be done.

With the development of the video industry, the personal computer and the widespread public use of the Internet, it has become increasingly more difficult for vested interests to suppress this type of development. The work of Tesla, Moray, Hendershot, Schauburger, Keely and Coler to name but a few - and more recently, DePalma, Adams, Searl, Stephen, Pons and Fleischmann, - all have developed devices that appear to have tapped into and utilised some form of invisible force. The fact is, the utilisation of this invisible force for the benefit of the human race, without resorting to the use of conventional fossil fuels or nuclear energy, must now be accepted as a reality and can no longer be denied.

In respect to the Hendershot devices, there are a number of parallels that already exist in the conventional world of electronics. The AC induction motor is one such device that uses the alternating field of the stator to react with a magnetised rotor that will be caused to rotate by the action of the induced field. It is but a simple step to consider the earth's electro-magnetic field as part of the stator, rather than just a set of conventionally pre-energised coils of wire..

On the other hand, it is not a difficult task to trick some circuits into believing that they have a conventional external power source from which to draw their energy. Such a circuit is used extensively in all fields of electronics and known as an oscillator or AC signal generator. In the following circuit we see it is supplied with an AC signal source such as a piezoelectric crystal, caesium molecules as used in the atomic clock, or a specially designed coil and capacitor to resonate at the desired frequency.

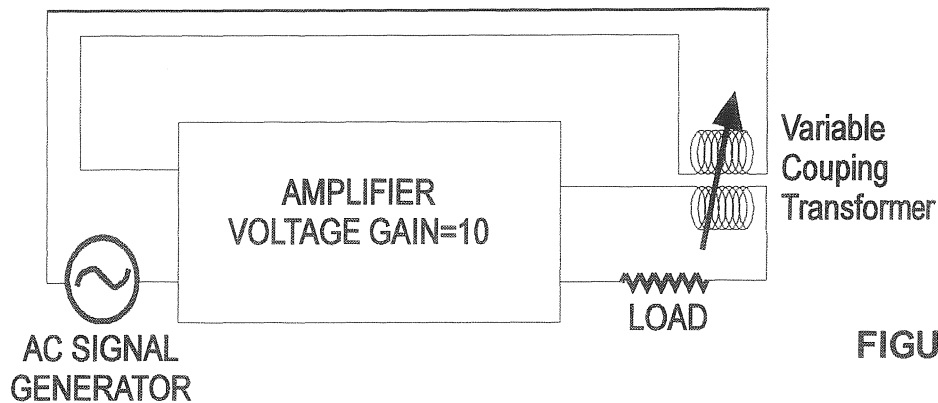
**FIGURE 1.1**

In this circuit the primary of a variable-coupling transformer is inserted in series with the load resistance of an amplifier. The secondary, in turn, is connected in series with the signal generator at the input terminals. These connections are to be made in such a way, that the voltage induced into the transformer secondary will always add to (rather than subtract from) the voltage provided by the signal source. This addition factor is vital.

Let us begin by decoupling the primary and secondary coils of the transformer so that no voltage increase occurs across the transformer. Then let us start the signal generator, adjusting it to produce say 10 volts of signal. Because the amplifier has a voltage gain (or amplification) of 10, the output voltage will be 100 volts. This is what we would expect.

Now let us increase the coupling within the transformer until the secondary induced voltage is 2 volts, meanwhile reducing the signal generator voltage to 8 volts. The amplifier goes on producing its usual 100 volts of output, just as before.

Then increase the coupling of the transformer to produce a secondary voltage of five, meanwhile reducing the signal generator output to 5 volts. Things in the amplifier go on as usual; it continues to produce 100 volts of signal output despite the fact that 50% of its input signal voltage is being developed by itself.

Finally, let us increase the coupling until the transformer secondary voltage is a full 10 volts, simultaneously reducing the signal generator voltage to zero. The voltage output of the amplifier continues to be a full 100 volts, despite the fact that the amplifier is now entirely producing its own input signal voltage. It is apparently too stupid to know that the external signal input has been completely removed.

Such an amplifier, arranged to supply its own signal input, is called an oscillator. When in operation, an oscillator acts as a convenient source of alternating current signal energy, and these are widely used in this way. Unlike a mechanical rotating-coil alternator of the power-plant type, the oscillator has no moving parts (except its electrical energy flow) and no bearings to lubricate. Furthermore, unlike the latter, it may generate voltages whose frequencies range from less than one cycle to billions of cycles per second and at power levels from microwatts to kilowatts.

Thus we cannot rule out the feasibility of a circuit that can utilise the rotating electromagnetic field of the earth as a signal or power source and then to continually reenergize and amplify this source by a compatible multiplying inductive or inductive and capacitive circuit.

If we consider the heat and light power from the sun that drives the process of photosynthesis and photo-electric cells, or the wind power that drives wind turbines, or the water power that drives our hydro-electric systems as free energy - then we must also accept - devices that utilise the electromagnetic field of the earth, or devices that tap the natural vibration of the energy field that surrounds all matter, or devices that exploit the energy field's natural potential density differences - also as free energy. And we must rewrite physics to accept that under these circumstances "We can really get something for nothing".

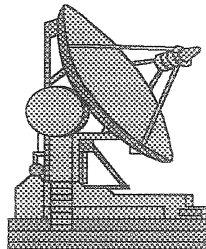

THE HENDERSHOT "FUELLESS" MOTOR

In 1996 Mark Hendershot released a drawing of an apparatus that he found in his father's papers together with some photo's of the same apparatus that Mark Hendershot believes to be details of his father's "fuelless" motor from 1927 or 28.

As Mark Hendershot indicates in the supplement to Appendix C attached, the drawing was very old and resulted in a poor copy quality. So, in the interests of clarity, I have reconstructed this drawing in Figure No 2.1 on the next page, and have appended a copy of the original drawing together with a bad copy of the photo at the end of this chapter.

The drawing in Figure No 2.1 appears to be identical in all respects to the rotor and excitation winding of a slip ring type alternator, with the exception of the external two slip ring configuration of the conventional alternator shown for comparison in Figure No 2.2 below the Hendershot motor. Hendershot has shown only a single slip ring - the second contact being made through a brass insulated button at the end of the shaft.

In a conventional alternator of this type, the enclosed winding is connected to a DC source (via the slip rings) to stimulate a polar magnetic field at right angles to the core, which in turn, increases the magnetic flux of the permanent claw-pole magnets indicated in Figure No 2.2. The purpose of the DC coil, in this case, is to regulate the intensity of the field, and thereby, the electrical energy output to the stationary surrounding coils (not shown), when the rotor, together with its central coil, is rotated as a body within the stationary windings.

Clearly, Lester Hendershot has made provision for some external circuitry via the brass button at the end of the shaft and the single adjacent slip ring shown in Figure No 2.1. Unfortunately, this external circuit is not shown and therefore cannot be analyzed. It may be that the external circuitry is nothing more than an on/off switch, or it could be some more complex arrangement of other components.

FIGURE 2.1

RECONSTRUCTION
OF HENDERSHOT
MOTOR
1928

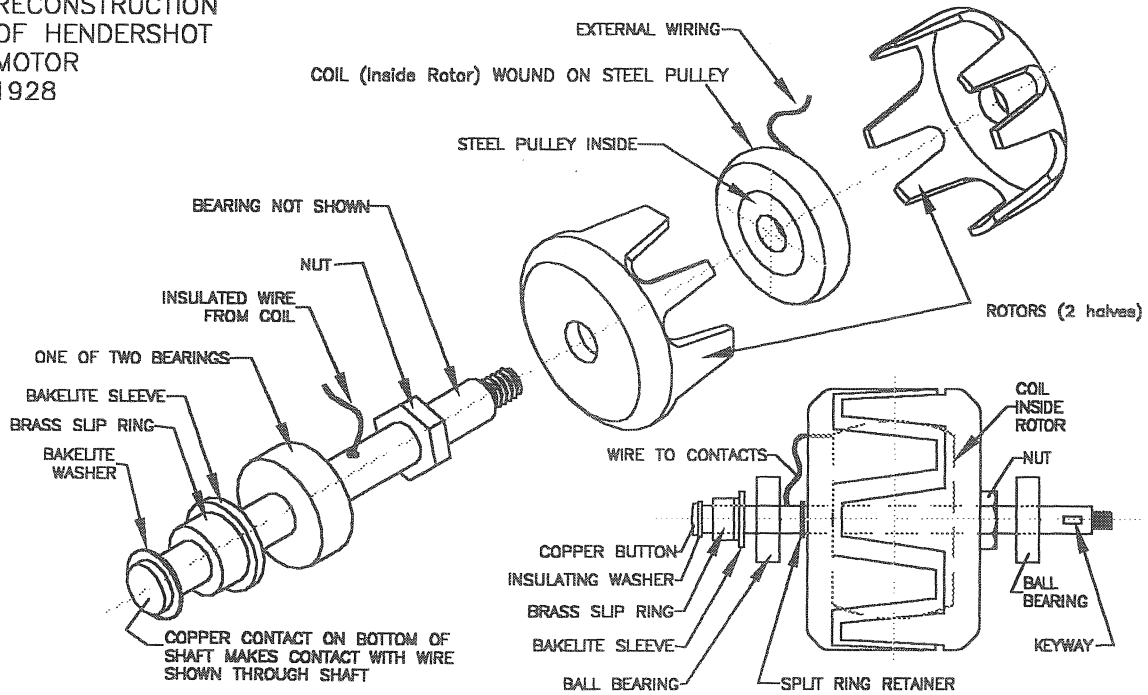
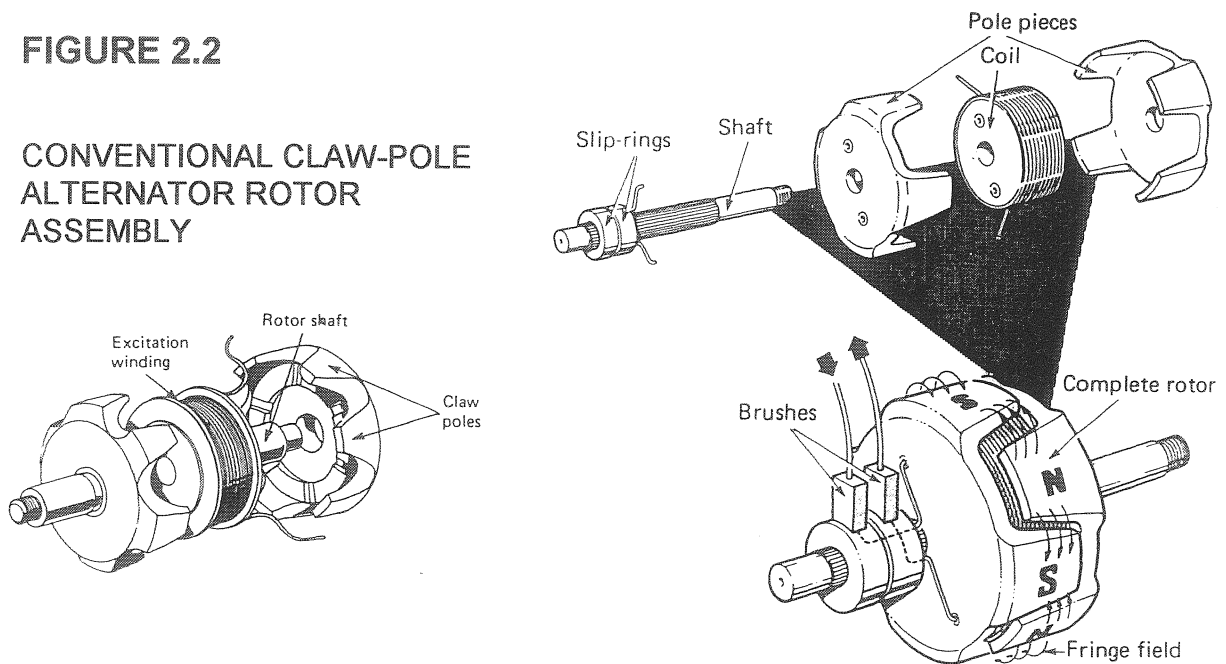

FIGURE 2.2

CONVENTIONAL CLAW-POLE
ALTERNATOR ROTOR
ASSEMBLY



From the mechanical point of view, it would be necessary for the rotor assembly, to interact with some external force to provide the rotary motion of the armature in order for the device to act as a motor. If the drawing in Figure No 2.1 is the complete device, with only an external circuit breaker connection, then there is no other external field for it to operate on, other than the earth's magnetic field.

Despite all our knowledge, we still know very little about the electromagnetic fields that surround the earth and how it may be possible to tap this source for human endeavour. We cannot therefore deny the possibility of tapping this inexhaustible supply of potential energy by just sticking our heads in the sand. It is not only possible, but irrefutably proven as fact in such devices as constructed by the genius of those mentioned previously, and also demonstrated by Hendershot in 1927 and 28. Although each has tried to account for the phenomenon in different ways, they have all achieved outputs that could not be explained in conventional scientific terms.

Consider the following. If the coil in the Hendershot device of Figure No 2.1, is provided with a closed circuit via its external connections, and the device be rotated through the bearings at a suitable angular velocity, then it can be shown that in certain positions, the permanent magnetic field of the device would interact with the magnetic field of the earth, although the earth's field would be considerably weaker than that of the permanent magnetic device. This magnetic interaction must provide a degree of change in the magnetic flux of the device, with its associated electromagnetic inductive effect on the central closed coil. The dynamic induced field would set up a potential alternating sine wave within the coils windings, which if amplified by the ampere turns of the coil, may result in a alternating phase shifted reactive flux in the permanent magnets. A resonant compatible circuit at a suitable frequency may therefore provide an action/reaction environment to cause the rotor to spin unaided provided the field in the central coil is sufficiently amplified to just cancel the permanent magnetic field of the magnets for each alternate half of the sine wave inductive impulse, and to intensify this field on the second half of the pulse. Whether or not this is fact or fantasy, remains to be seen.

The reality is, that Hendershot did succeed in this remarkable achievement, and the details shown in Figure No 2.1, are possibly the principle components used in the Hendershot "fuelless" motor.

It was reported in the New York Times on 26th February 1928, that in late 1927, Lester Hendershot built a model aircraft that was powered by a "Fuelless" electric motor to drive the propeller. This model he demonstrated at Bettis Field, in flight, to D. Barr Peat, the manager of Bettis Field Airmail port, near his home in Elizabeth. Evidently Peat was so impressed, that he arranged for officials of the Army Air Force base at Selfridge to witness a demonstration at the Selfridge Field.

From an article in the NYT Feb 26, W.B. Stout, the head of the Stout Air Lines and an aircraft engineer, also witnessed a demonstration of this motor together with representatives of the Ford Motor Company at the Pittsburgh demonstration (probably in Jan or Early February 1928). Stout described the motor as about the size of a tiny electric motor used in vacuum cleaners and was advised (probably by Hendershot) that the armature had been wound in a special way to draw energy from the earth's electromagnetic field. Stout made no mention of any other components except the motor. Like Peat, he too was very impressed, saying that it was uncanny and worked exactly as Hendershot explained that it did.

In an article in the NYT Feb 28, 1928, Hendershot is reported as saying that the forces that energizes it, is the same force that pulls the needle of the compass around and that he used a pre-magnetized core. In continuing his experiments, he found that by cutting the same line of magnetic force, east and west, he could develop a rotary motion. He went on to say that he now had a motor built on that principle that will rotate at a constant speed, a speed predetermined when the motor was built and can be built for any desired speed.

In the same article, Peat declared "The main secret of Hendershot's invention is the method of winding a magnet in the motor so that it will rotate in the opposite direction than the earth revolves."

In another article in the New York American on 27th February 1928, Hendershot is reported as saying "The engine actually makes its own electricity. There is a magnet which acts as a starter. From that point on it generates its own power. The magnet will not wear out under 2000 hours, nearer 3000", "the motor is not the size of a vacuum cleaner motor. It is twenty-eight inches long. It weighs 130 pounds, and it has developed 45 horsepower at 1800 revolutions a minute." In November, he is reported as stating he had developed a motor with an output of 60 horsepower.

In a report by Hendershot's wife in the NYT on 26th Feb. 1928, it is stated that the first model used a miniature motor which Hendershot had placed in a small model plane he had constructed for his four year old son. It said a switch was turned, and immediately the propeller began to move. It further stated, the machine was not connected to any electrical power. It went on to state, the little motor and airplane rested upon a small table in the living room of the Hendershot home, and later was demonstrated at Bettis Airfield. It also stated that the motor would only work when pointing north and south and would not work when pointing east and west.

From the above extracts of the newspaper articles transcribed at Appendix A, there appears to be some contradiction either in the reporting or the statements given by the various individuals. For some reason, Hendershot wished to hide the fact that the small airplane motor existed at all. It is blatantly obvious, that both Hendershot's wife and Stout made statements that Hendershot didn't want to be made public. Maybe he thought those statements could compromise a future patent claim or funding. There is however, collaborating statements given by Stout, Hendershot's wife and his mother, when referring to the miniature motor in the model aircraft. So Hendershot's statement that these reports were incorrect is not borne out by the evidence, except that he claimed to have perfected a motor that works in all directions..

The statement given by his wife, that when the switch was closed, the propeller began to move, may not be strictly correct. It is more than possible that the propeller would need to be given some impetus in order to start a reaction within the windings, unless the solid state device (referred to in the next chapter) was incorporated as part of the circuit. It is also possible that the re-created design shown in Figure 2.1, has nothing to do with the original model motor, in which case, the analysis would be fruitless. On the other hand, the design shown in Figure 2.1 and the poor photographs of the same device shown in Figure 2.4, may be of the motor described by Hendershot above, being 28 inches long and weighing 130 pounds.

His wife is reported to say it worked only in the north/south direction, whilst Hendershot states he produced the rotary motion in the east/west direction. Without experimental evidence, it is hard to comprehend which statement is the more probable. Clearly, the winding in the coil of Figure 2.1 could only be cut by the earth's magnetic field if the device was pointing north/south along the shaft. A different consideration, is that the magnetic flux between the poles would only be disrupted if rotated in an east/west shaft direction and this in turn would cause a fluctuation within the core winding.

Despite these contradictions, some firm assumptions can be made as to the truth of the saga.

1. The motor demonstrated at Bettis Airfield was undoubtedly the small model about the size of a miniature vacuum cleaner motor. It is certain that a 26 inch long 130 pound device could hardly fit in a small model aircraft on a small table in the living room, let alone have sufficient wing span to lift it off the ground.
2. By the same reasoning, such an electric motor would have needed to be self contained without all the accessories referred to in the next chapter. If it did contain all the solid state device as well as the motor, this too, would have been too heavy to become airborne.
3. Assuming that the small motor was of the same (or similar) design to Figure 2.1, it is clear that the hardware could comprise of no more than the armature assembly shown, an external switch and maybe some type of collector/oscillator circuit and antenna similar to that shown in the next chapter. Anything more, would likewise be too heavy to get off the ground.
4. The design shown in Figure 2.1, does not lend itself to any exotic style of winding on the pulley core, other than a conventional bobbin winding of the type used in a conventional alternator of similar design. The statement given to Stout by Hendershot that the motor contained a special type of winding, was either intended to mislead, or referring to part of the external circuit.
5. The motor referred to by Hendershot above, may relate to one built by the engineers at Selfridge Airfield during February 1928, under Hendershot's direction and from parts available at the airfield. If this motor had been available for demonstration some three weeks earlier at Bettis Airfield, Hendershot would have been a fool not to have demonstrated it to potential backers. If it had been shown to Stout, he would have not made the statement "I would like very much to see how a larger model designed to develop power enough to lift an airplane would operate." 45HP would certainly have been enough in those days to lift a manned small craft of sufficient wing span.

In the 1920's, the two slip ring idea shown in Fig. 2.2 had not been developed. It was then common practice to earth one side of the coil to the shaft and to connect the other end of the coil to a button as shown in Fig.2.1. - The external circuit was then connected across the shaft and end contact with brass rubbing contacts. It is plausible that the button contact was used for an oscillating circuit breaker attached to an antenna and maybe connected to the detector/collector circuit of the Mark II design discussed in chapter 4.

7. It is clear that the motor referred to as the Hendershot motor was not a conventional motor used in the output circuit of the solid state device. If it had been, Major Lanphier would not have made the statement to the NYT on 27th February 1928: "I saw the first model which Hendershot built hooked up to a small electric motor of the type used to operate a sewing machine. It not only ran that motor but it burned it out." The Hendershot motor, was therefore an entirely different device to the solid state generator, which Lanphier stated kept a 100 watt lamp going for twenty-six hours (See next chapter).

CONCLUSION

Despite the information provided by Mark Hendershot, there are too many variables to determine exactly how the Hendershot motor was constructed. It is not even certain that the drawing provided by Mark Hendershot is actually part of the larger motor, or a drawing of something else Hendershot was experimenting with.

There are many alternators of the type shown in Figure 2.2 designed for cars and motor cycles that can be purchased from any local wrecking yard at very little cost. Any enterprising backyard inventor could spend many hours tinkering with a modified alternator as shown in Figure 2.1, and with a little luck and ingenuity may just be able to re-create what Hendershot did some seventy years ago.

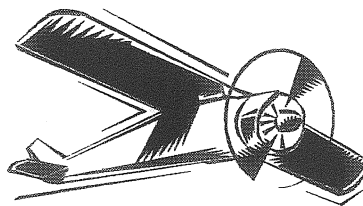
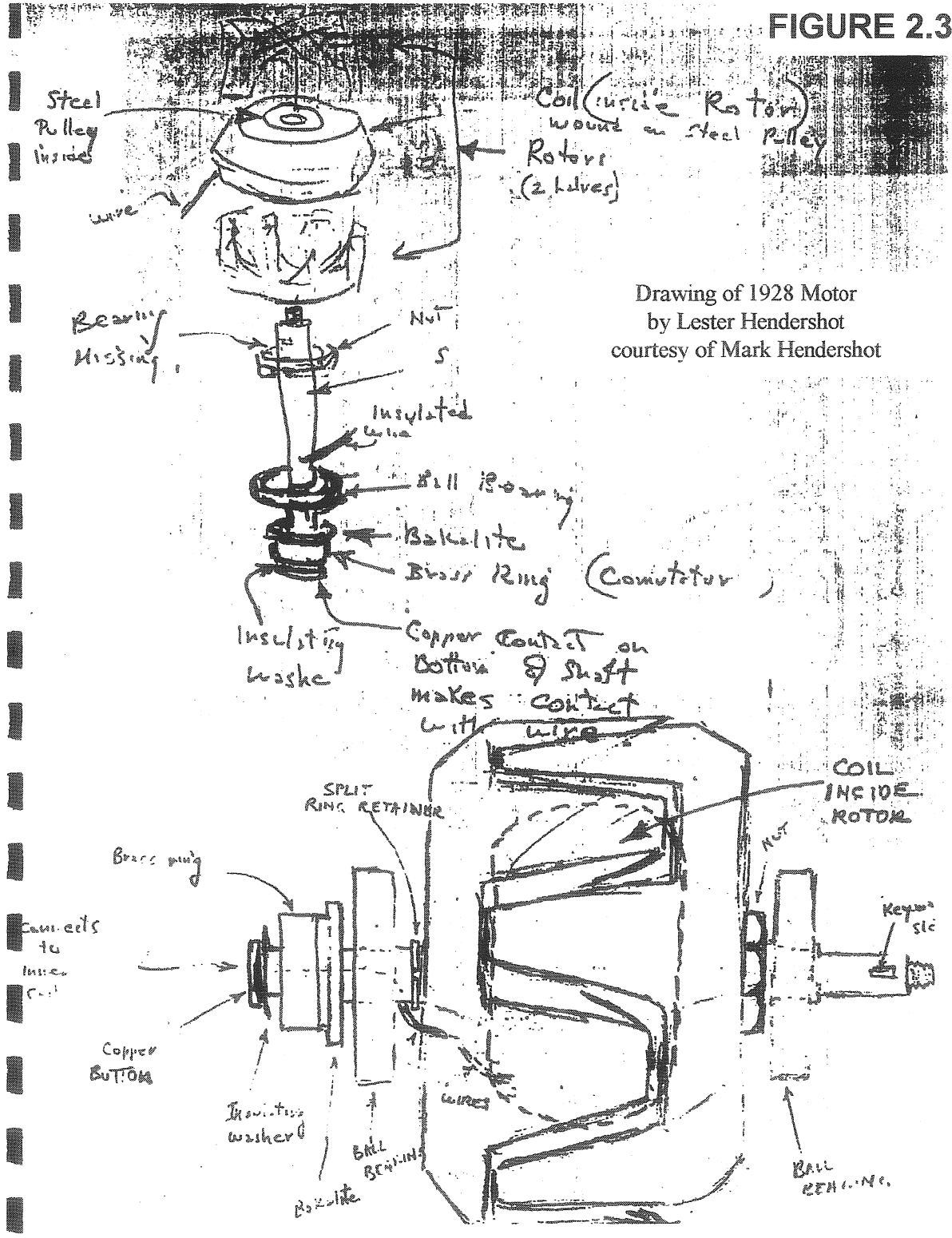

FIGURE 2.3



Drawing of 1928 Motor
by Lester Hendershot
courtesy of Mark Hendershot

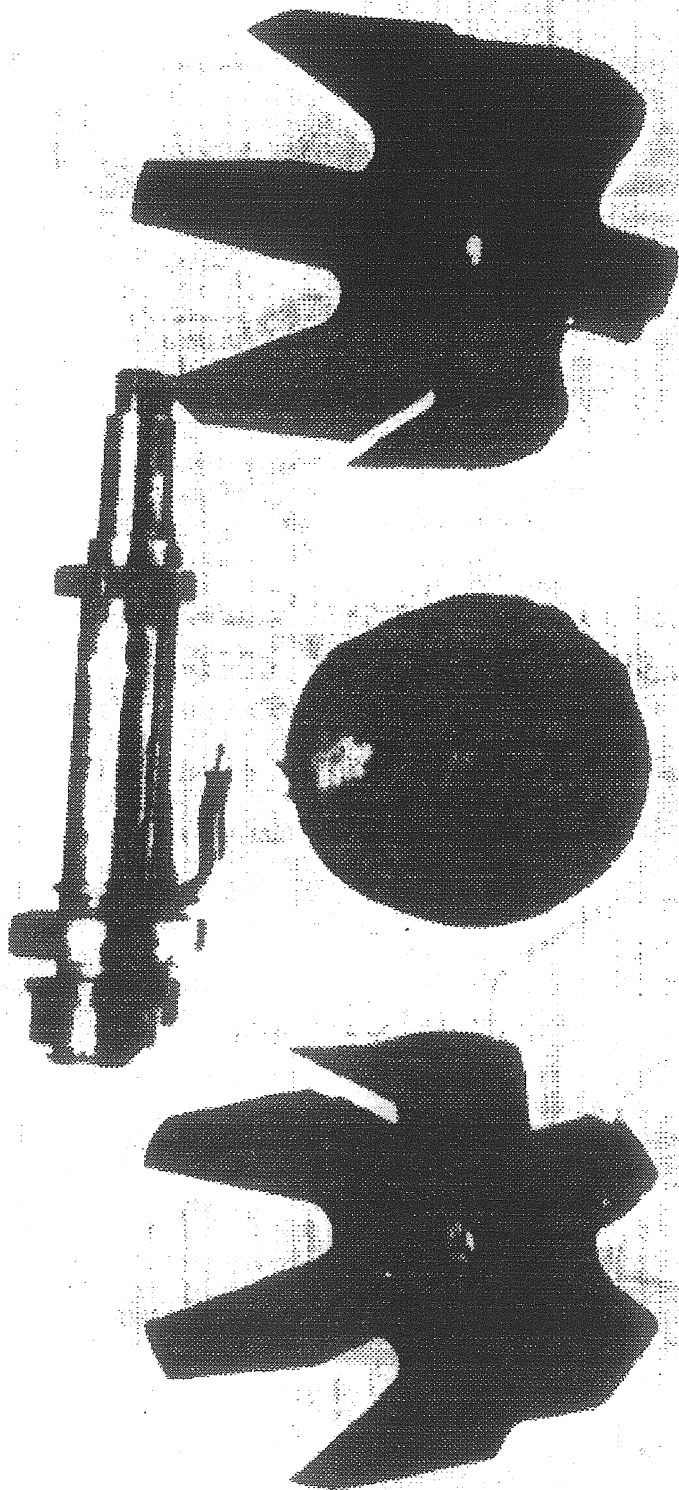

FIGURE 2.4

Exploded view of 1928
Hendershot Motor
courtesy of Mark Hendershot

HENDERSHOT'S SOLID STATE GENERATOR

Until 1995 no one, other than those directly involved, had any idea of what the devices demonstrated in 1927/28 looked like, let alone how they were constructed. But fortunately for posterity, Mark Hendershot in 1995 publicly released some of his father's documents which contained a rough sketch and patent draft for what appears to be a solid state generator. But it is not certain if this device was ever demonstrated at Selfridge Airfield all those years ago. (See Appendix C & D)

Unfortunately, the drawing contains an elevation that does not show all of the components. However, analysed in conjunction with the accompanying patent draft and some pertinent information contained in the covering letter from the patent solicitor, I have managed to reconstruct the entire device in the two different variations as Hendershot had created them. From this reconstruction, I have also been able to prepare complete circuit diagrams, but as no mention was made of the wire thickness, the number of turns used, or the coil sizes, then it will be up to the experimenter to fill in these missing blanks.

I have called the first generator device "Mark I" (I hope Mark Hendershot doesn't mind the pun) - and I have called the second generator device "Mark II". There is also a third generator device that Hendershot created at a later date (probably in the 1950's), the details of which were released in an article by Ed Skilling in 1962 and referred to in Arthur C. Aho's book on Hendershot, entitled "Energy Unlimited - A Case for Space" published in 1968. This third device has also been designed in a number of different configurations, which I will individually refer to as Mark IIIA, IIIB, etc., when I discuss the Mark III series later in the book. For now I will concentrate on the Mark I.

On the following page, I have reconstructed a side sectional elevation of the Mark I Hendershot Fuelless Generator in Figure 3.1. This drawing has been slightly modified from Hendershot's original (See Figure 3.8) to conform to standard drawing practices. The original drawing however, is of the Mark II design and will be discussed in the next chapter. The coded component numbers listed in Figure 3.1, refer to the same codes as used by the patent solicitor in his draft detailed in Appendix D, and may be referred to later to confirm my analysis.

The Detector/Collector circuits consist of two separate circuits, which I assume is supposed to be tuned to interact with the earth's electromagnetic field. For the purpose of the exercise I will adopt this explanation as a definition - irrespective of its true nature.

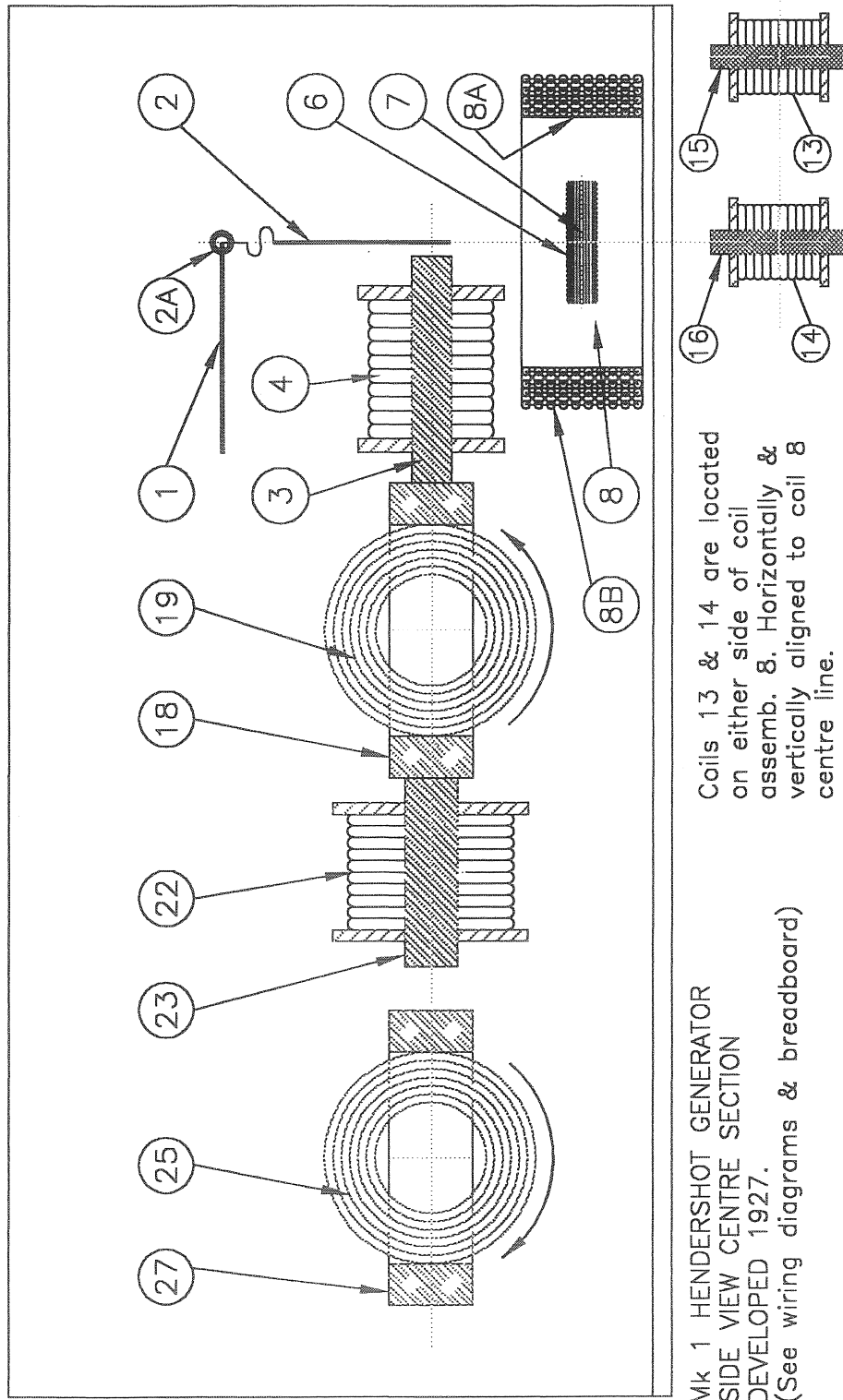

Coils 13 & 14 are located on either side of coil assembly, 8. Horizontally & vertically aligned to coil 8 centre line.

Mk 1 HENDERSHOT GENERATOR
SIDE VIEW CENTRE SECTION
DEVELOPED 1927.
(See wiring diagrams & breadboard)

FIGURE 3.1

The first part of the Detector/Collector circuit comprises components:

- (1). Metal Antenna plate (1)
- (2) Steel oscillator strip (2)
- (3) Tuning coil (6) - wound on permanent magnet (7)
- (4) Honeycomb cross wound coil 8A of a single layer of wire, &
- (5) Honeycomb coil 8B outer winding - identical to 8A.

This part of the circuit is shown schematically in the following diagram Figure 3.2.

CIRCUIT No 1 - HENDERSHOT MARK I POWER GENERATOR

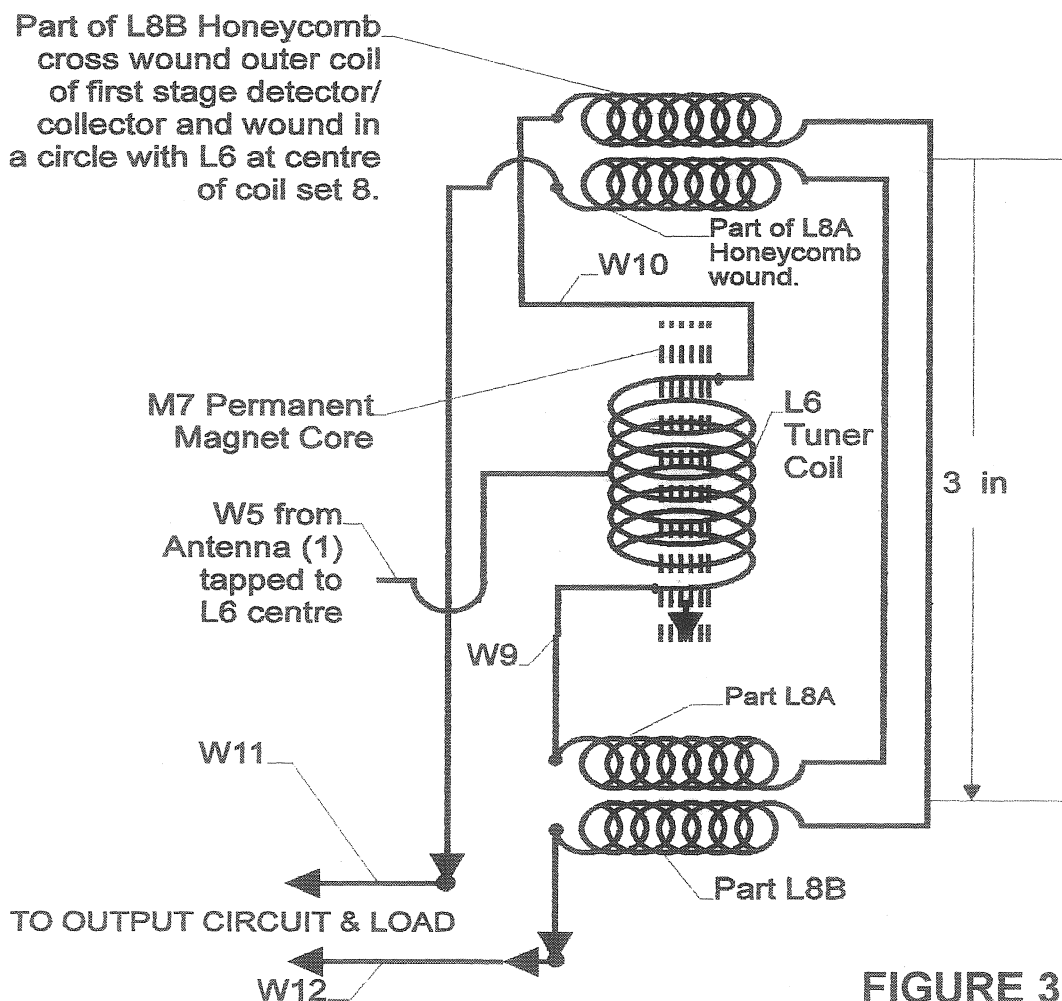

FIGURE 3.2

From Statement 22 (Part 2 Appendix D) it is stated that the Honeycomb windings (8A & 8B) consisted of one layer each of a single wire cross wound. This statement also claims both (8A) and (8B) are identical.

There is no mention of a special core for these windings anywhere in the document. If it was wound on a soft iron ring core or permanent magnet, it would have been mandatory for this to be included in the claims. It may therefore be assumed the coils (8A/B) are wound on a non metallic former.

There is also nothing to indicate whether these coils are wound in the same direction or in opposite directions. As this specification has not been included, it may also be assumed that they are both wound in the same direction, but this is not certain. If coils 8A and 8B had been diametrically wound, it would have been specified in the draft, (as is the case with coils (13/14) and coils (19/25)).

The 3 inch diameter of coils (8A/B), is a guess based on the statements on coil sizes given by Major Lanphier on 27th Feb 97 in NYT, but it may not relate to this device.

There are a number of ways coils (8A and 8B) can be wound on the former, but there are only two methods that are most likely. I will discuss this a little later. Unfortunately, this specification has not been included in the draft patent and must therefore be defined by experiment.

It will be noted that coil assembly (6/7) is situated in the exact middle of coil assembly (8A/B), and has a transverse relationship as defined in Claim 4, App. D, Part 3. That is, the axes of coil (4) and coil (6) are parallel, whilst the axis of coils (8A/B) is vertical. The patent diagram (Fig 3.8) and Figure 3.1 show the orientation of coils (8A/B). The coil (6) is probably a short coil of a single layer of heavy wire, and possibly around $\frac{3}{4}$ inch to 1 inch diameter (a normal radio coil tuned to 500 kcps might be a good starting point, as this is the frequency used in the Mark III device). It most probably does not cover the entire length of the magnet.

The polar orientation of the round bar magnet (7) as the core for coil (6) is not given, and must be determined by experiment. The magnet (7) is probably about 2/3rds the inside diameter of coils (8A/B).

The second part of the Detector/Collector circuit comprises:

- (1) Coil (4), wound on a soft iron core (3) (bobbin wound),
- (2) Coil (13), wound on a soft iron core (15) (bobbin wound), &
- (3) Coil (14), wound on (16), identical to (13)/(15).
- (4) In between coils (13) & (14) is connected an X meg ohm resistor (17) in series.

This second part of the circuit is shown schematically in the following diagram - Figure 3.3.

CIRCUIT No 2 - HENDERSHOT MK 1 OSCILLATOR/COLLECTOR DESIGN

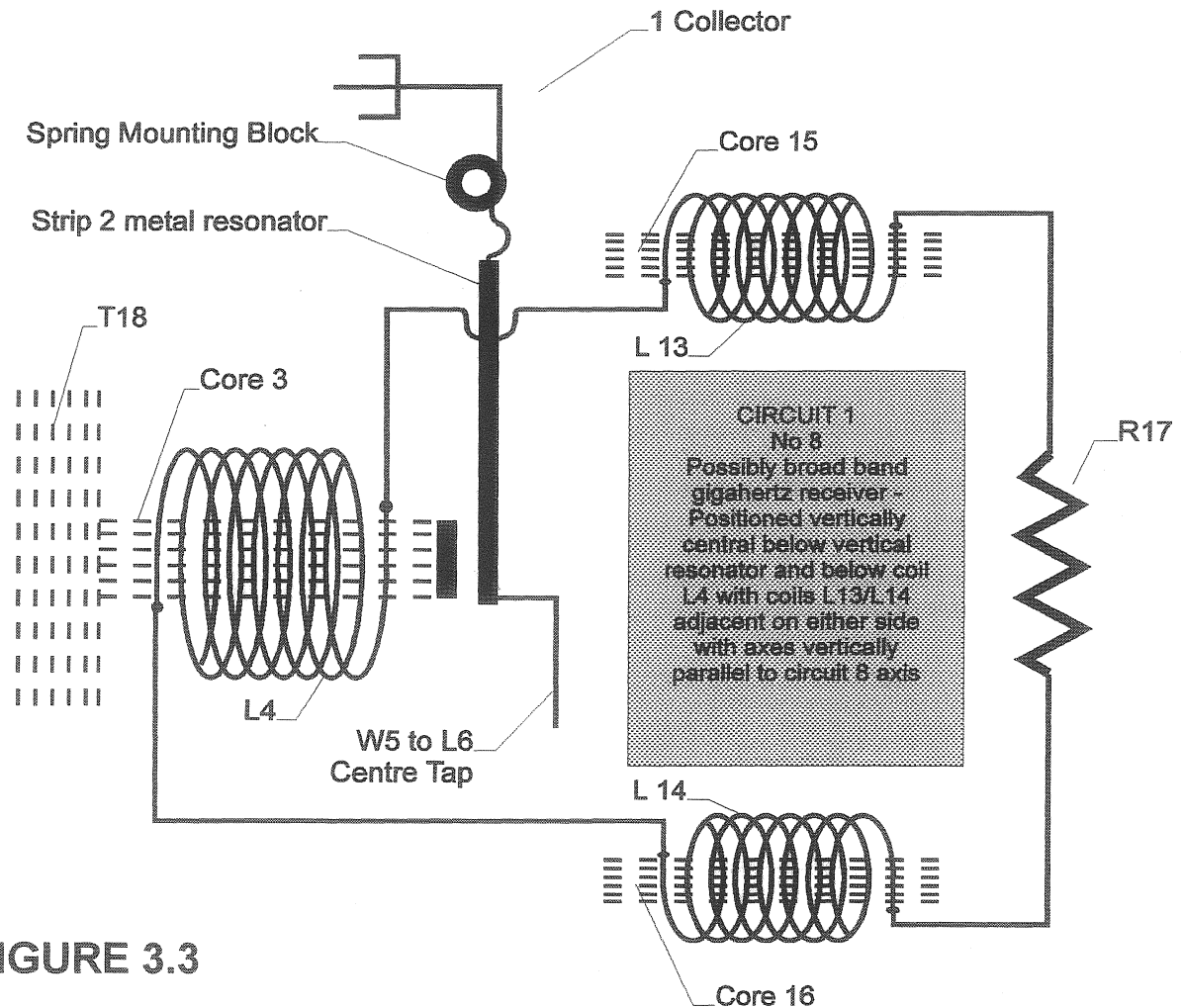

FIGURE 3.3

As can be seen, the circuit in Figure 3.3 consists of three bobbin wound coils each with a soft iron core and connected in series with a megohm blocking resistor (of unknown value) connected across coils (13 and 14). The circuit is coupled magnetically to the Output Circuit No 3 directly to Transformer (18) by a solder joint between one end of core (3) and the outer frame mid point of (18) as specified by Statement 12, Part 2, App. D. It is also inductively connected to the collector/detector circuit No 1, via the honeycomb coils (8A/B) and the adjacent coils 13/14. Coils (13/14) are wound in opposite directions and are connected to coil (4) accordingly. See Statement 10, Part 2 App D.

The axes of coils (13/14) and (8A/B) all point vertically upward with (13/14) placed one on either side of coils (8A/B) and lined up along the centre diameter line of coil assembly (8A/B) and perpendicular to the axis of coil (4). See Statement 11 and 18 of Part 2, App. D. Note: Statement 18 has a little ambiguity, accordingly there is an outside possibility that the axes of coils (13/14) may be in a horizontal direction, the same as coil (4).

In the vertical plane, both coil assemblies (3/4) and coil assemblies (8A/B), are arranged so that their axes intersect at right angles at the lower portion of resonator/oscillator (2). The gap between the end of core (3) and the resonator (2) is unknown and will need to be determined by experiment.

It will be noted that in the original sketch of this device shown in Figure 3.8 and also in the circuit diagrams shown above, that wire (5) is connected to the bottom of the oscillator (2). It is my belief that Hendershot intended for this connection to be made directly to the antenna plate (1) and not to the bottom of oscillator (2) as shown. This belief is supported by a statement in the covering letter that accompanied the patent draft. Evidently the draftsman had decided to make this change, not realizing, that to connect wire (5) to the bottom of oscillator (2) would interfere with its function. (See Appendix D.)

The output circuit comprises:

- (1) Coil (19) inserted into the outer frame (18) of a laminated transformer without a central core - Many turns fine wire.
- (2) Bobbin wound coil (22) of heavier wire on soft iron core (23),
- (3) Coil (25) in transformer frame (27) - identical to (18)/(19).

The schematic of this circuit is shown in Figure 3.4

CIRCUIT NO 3- MK I & II HENDERSHOT POWER GENERATOR OUTPUT CIRCUIT

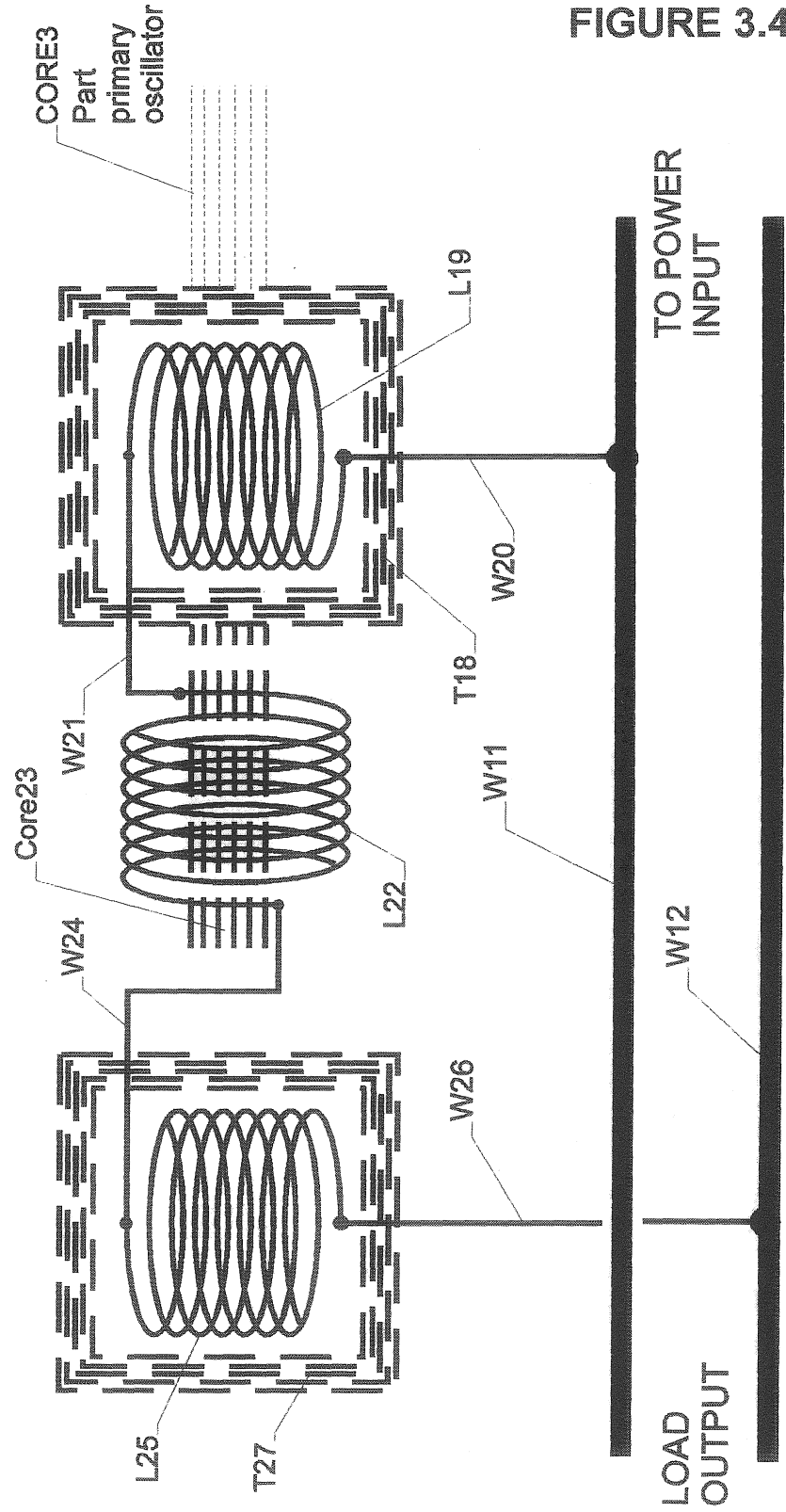

FIGURE 3.4

This part of the circuit in Figure 3.4, is clearly described in Part 2, App. D, Statements 13 to 16, as follows:

The transformer plate set (18) & (27) are identical and have openings in their centres for the reception of the fine wire coils (19) & (25) respectively - these coils also being identical. There is no core in either of the coils (19) or (25).

The inner end of coil (19) is connected to power line (11) via wire (20), and the outer end of coil (19) is connected by wire (21) to the inner terminal of coil (22). The outer end of coil (22) is connected to the inner terminal of coil (25) via wire (24), with the outer terminal of coil (25) connected to the power line (12), via wire (26). The windings of coils (19) & (25) are in a diametric relationship across coil (22) as shown in Figure No 3.1.

The windings of coils (4)&(22), are both wound in the same direction. The patent draft does not specify if these winding are clockwise or anticlockwise when viewed from the output end of the circuit. There is a directional arrow on the original sketch, which - to me - seems to be indicating a clockwise rotation of coils (4)&(22), when viewed from the output end of the device, but its location is so ambiguous, that it could be indicating an anticlockwise rotation. See original sketch Figure 3.8.

The load is connected across the output circuit via wires (W11) and (W12) and also electrically connected across the primary input circuit No 1 via takeoff terminals from (8A) and (8B).

Coils (19)&(25) are respectively place inside the outer square transformer laminations of (18)&(27) respectively and the orientation of the entire output assembly (including coil assembly (3/4) is as shown in Figure 3.1 and arranged in a line symmetrically around the centre line of each component.

It should be noted from Figure 3.1, that the soft iron cores (3/23) of coils (4/22), are electro-magnetically connected to transformer frame (18) (by soldering) as indicated. The other end of core (23) and Transformer frame (27) is to be separated by an air gap (The distance of which has not been specified and must be determined by experiment).

The entire circuit diagram for the Mark I generator is shown in the following schematic - Figure 3.5.

FULL CIRCUIT OF THE LESTER HENDERSHOT MARK I AC POWER GENERATOR DESIGNED LATE 1920'S

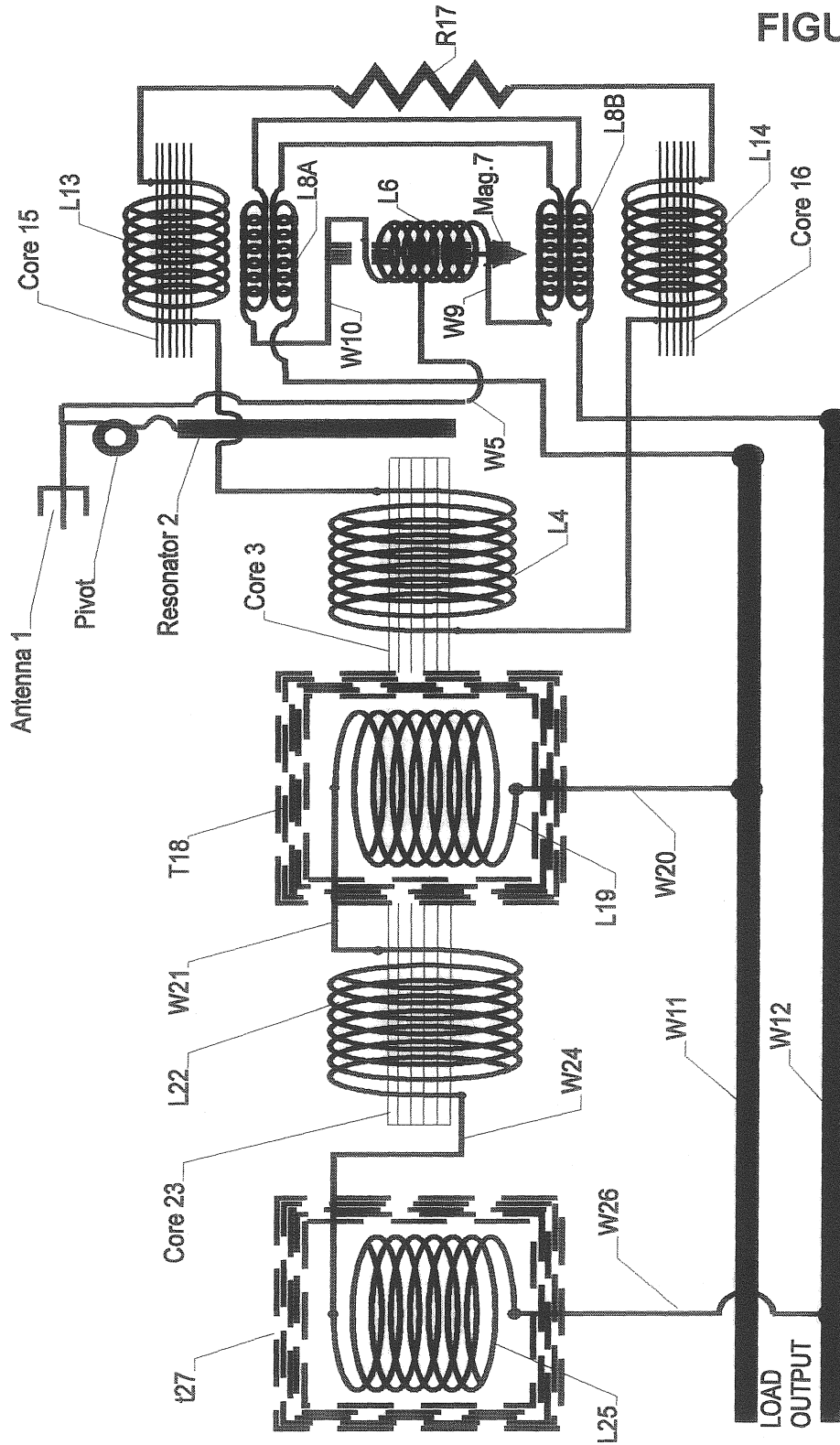
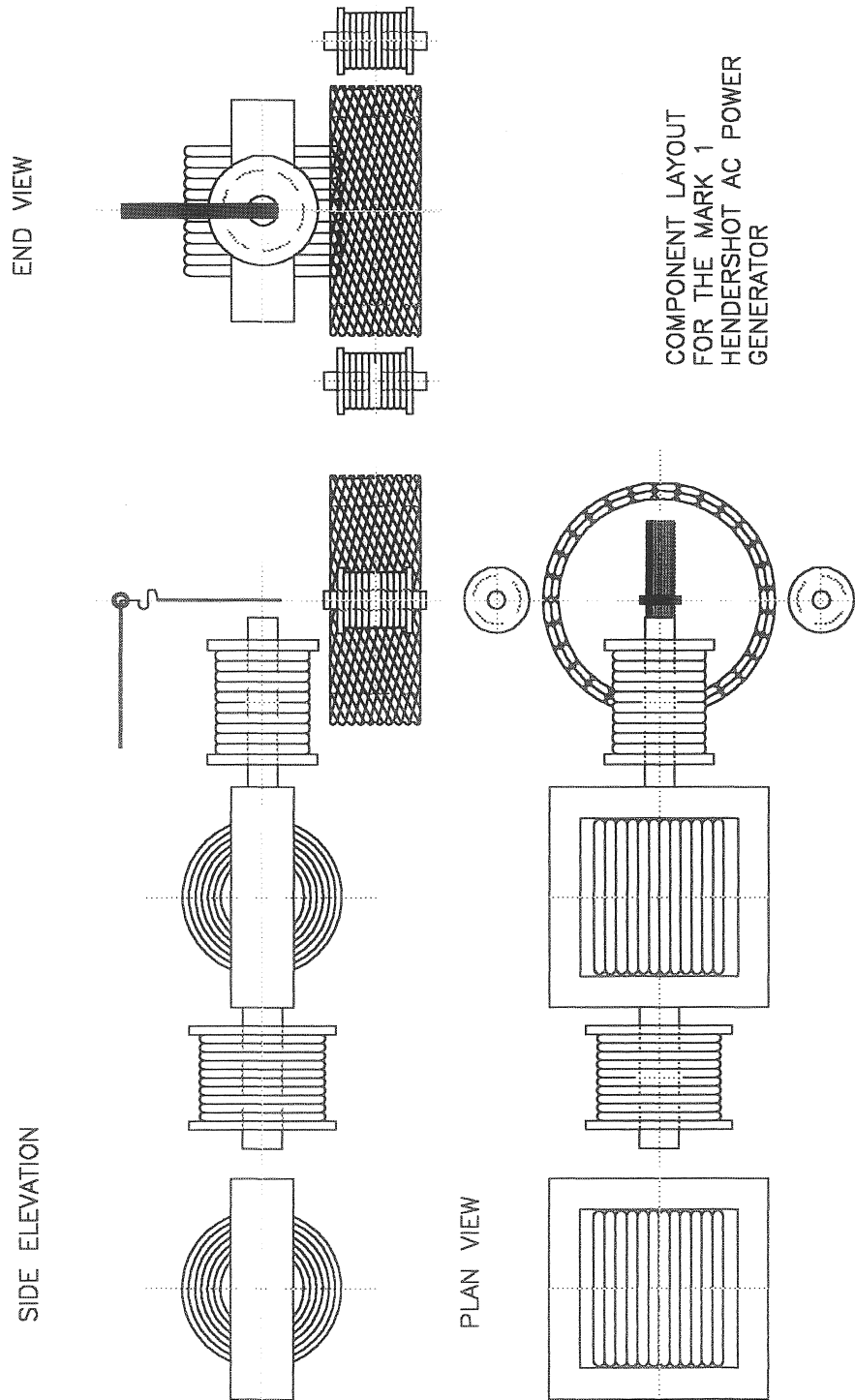

FIGURE 3.5

For circuit details see Circuit drawings No 1, 2 & 3 for the Mark 1 design and next chapter for the Mark II modified circuit and the Full circuit of the Mark II design.. Detailed information regarding these designs is given in the text and Appendix D.



COMPONENT LAYOUT
FOR THE MARK 1
HENDERSHOT AC POWER
GENERATOR

FIGURE 3.6

LAYOUT OF MARK I COMPONENTS

As this is substantially an inductively coupled circuit assembly, it is important that the components be arranged in the correct layout and orientation. Accordingly, I have intensively analysed the patent specifications, and consider the perspective drawing Figure 3.6, is the most probable layout for the Mark I design with at least 95% accuracy.

It will be noted from the side section/elevation, that there are three horizontal planes to the device. The lower plane consists of coil assembly (8), which includes the tuning coil (6) and its core (7) at the centre of coil assembly (8), plus the two soft iron core coil assemblies (13/15) and (14/16), situated outside and adjacent to the coil assembly (8). The middle plane consists of the output circuit starting with the coil assembly (4/3), then transformer assembly (18/19), then coil assembly (22/23), and ending with transformer assembly (25/27). The top plane consists only the flat iron collector plate with its vertically connected mechanical iron resonator/oscillator terminating at the centre of core (3), and vertically above the centre axis of coil assembly (8).

It should be noted that the axes of the antenna (1), coil assemblies (4), (22) and (6) are all parallel and pointing in the same horizontal direction, whilst the axes of coil assemblies (19) & (25) also point in the horizontal plane, but at 90 degrees to (4&22). Coils (8A/B) & (13/14) are perpendicular to coil assemblies (4) & (22), but their axes point vertically up.

From the plan view, (Fig. 3.6), the assembly forms a "T" shape, with the lower leg of the "T" forming the output circuit. Coil assembly (8) has its axis at the junction of the "T", with coil assemblies (13) & (14) at the extremities of the top leg of the "T". Coil (13/15) is on the left of the "T", and coil (14/16) is on the right. The antenna is not shown, but is vertically above coil assembly (3/4) with a horizontal extension. Thus the entire device has a balanced vertical and horizontal alignment.

The draft specifications allow for two different variations of the design shown above.

- (1) In Part 2 of Appendix D, Statement 14 claims that core (23) may be omitted. *Statement 14 is the only statement that mentions the metallic coupling of (18) and (23). All the rest of the claims refer only to a coupling between (3) & (18), although the original drawing shows otherwise.*

- (2) In Part 3 of Appendix D, Claim 7 states interalia "the third coil (22) arranged at right angles to the first coil (4)". *I believe this statement is an error, as Part 2 Statement 20 states the output circuit is unchanged. Also Claim 7 is specific to Mark II design. If this is a genuine variation, then the axis of coil (22) should point vertically up, in keeping with the perpendicular relationship of adjacent components as shown in the design, and coil (22) placed midway between coil (19) and (25) with or without its soft iron core (23) in place.*

The size relationship and dimensional placement of parts in Figure 3.6 is about the same as the original sketch at Figure 3.8, and may be used as a guide in determining component scale sizes and coil windings.

As a starting point, one may apply an educated guess of the components used by Hendershot in the 1920,s:

1. The two transformer assemblies (25/27) & (18/19), were probably parts from an old radio with just a primary and secondary winding of the standard three post lamination design (sometimes called an "E" type or "H" type transformer). These are small transformers of about 2 1/2 - 3 inches square. In the older style of transformers of this type, it was easy to remove the primary winding and centre lamination post whilst still leaving the secondary fine wire core in tact and still contained in the outer frame laminations. Thus it is a good bet that Hendershot didn't even bother winding a special coil for either (19) or (25) and just used the existing secondary winding and the outer frame of the transformer (The primary and centre post laminations he removed and discarded). In his later experiments (See Mark III design), he stated he found the TV vertical oscillator transformers, with a 5:1 secondary to primary winding, worked better.

2. It is stated by Skilling (see Appendix B), that Hendershot had a fondness for using the bobbin wound coils from old bell ringing circuits with their soft iron cores. Although Skilling reported that the coils used in the Mark III oscillator were mains (110 volt) type, the ones used in the Mark I & II designs are probably battery operated bell ringer bobbins, because the wire used in the mains type may have been too fine and comprised of too many turns. Although it is not stated directly in the Patent draft, it is obvious from the text the wire on the bobbins, are of a heavier gage than in the transformers.

3. Hendershot used mainly three wire gages in his devices, namely: American Wire Gage 28 (0.0136" dia.), 24 gage (0.213" dia.) and 20 gage (0.0334" dia.). From this it may be assumed that the transformers are wired with AWG 28, whilst the bobbins are probably wired with either 24 or 20 AWG. It is also possible that he used the primary windings from the original transformers to wind the bobbins. The honeycomb windings would also need to be substantial and are probably would from either 20 or 24 gage. It should also be noted that the very early induction coils used silk or cotton covered wire instead of lacquer insulation. Whether the insulation would make any difference to the success of the finished device is uncertain. However, his Mark III devices used TV transformers that are lacquer coated, so it probably would make little difference which coating was used.

4. If it is assumed the Honeycomb coils are the forerunner of the Basket weave coils Hendershot used on his later devices, then the pitch (gap) of each honeycomb square, is probably the same as the radial pitch, or gap width of the basket weave coils ie., 6.316 degrees or 0.33 inch squares. As no mention is made of a diametric winding for coils 8A and 8B, it may be assumed these are both wound in the same direction.

5. There is also some question of the method the windings are wound on the former. Modern honeycomb coils are normally wound with a reversal of direction across the coil every 180 degrees, plus or minus the pitch of one crossover, to allow for a progressive even cross winding around the entire coil. (This is similar to the winding of a ball of string or a modern cotton reel.) It is also possible that he reversed the direction at every second pitch width, to end up with a even layer around the coil of the correct pitch. It is therefore up the experimenter to try different combinations in an attempt to solve the problem.

6. I suggest one starts with a three inch diameter coil with a cylinder height of say 1 ½ inches. The former could be a short length of PVC pipe or cardboard wrapped in a cylinder shape. If you don't have access to a professional honeycomb winder, then two circles of ½ inch chip board can be partly inserted in each open end of the former. Around the outer circumference of the chipboard, an odd number of pins or small nails are inserted evenly spaced around the circumference, so that part of the nails stick out to act as binding posts. Start with 57 nails equally spaced and align both discs so the nails line up across the coil former. Try a number of different coil winding arrangement using the heavier wire gages suggested.

When you finish the windings, remove the nails and then the chipboard disks. What you are left with is a finished honeycomb weave coil. Don't forget to use varnished insulated copper wire used for magnetic windings. You could also try winding 8A and 8B in different directions. It might take a few weeks work, but if you succeed, the result will be worth the effort. And the cost will only be a few meters of wire.

7. The size of the components will be initially determined by the transformers used. All other components should then be sized to roughly the proportions indicated in Figure 3.1.

I have already made some suggestions regarding the tuning coil (6). It is almost certainly made from a single layer of heavy gage insulated wire in a continuous close set winding. Start with about an inch long coil of about $\frac{3}{4}$ in to 1 inch dia., and work up from there.

8. It may also be that the device requires some form of starting mechanism, such as a battery temporarily connected in circuit (Figure 3.3), to get the buzzer working properly. I don't think the windings in the output circuit (Figure 3.4) or the induction circuit (Figure 3.3) are all that critical, as these two parts of the circuit only seem to serve as magnetically inductive amplifiers, possibly heterodyned to a usable frequency by the mechanical oscillator. The critical part is most probably circuit (Figure 3.2). If you can get this right, it should be possible to achieve some result across the load terminals either with a small light globe or a reading with a meter or oscilloscope. I am assuming of course, that Hendershot would not have initiated the patent draft, unless he had previous success with this design, and also assuming the patent attorney has correctly described the device.

One does not need to be a genius to see what Hendershot has setup this device to do. Instead of alternating a current flow within a coil of wire by passing the wire mechanically through a rotating magnetic field, he is varying the magnetic field itself to induce the alternating potential difference within the closed wired circuit. The mechanical input is achieved by the self perpetuating natural harmonic oscillation of the resonator (2), which in turn is achieved by the correct tuning and positioning of the collector/oscillator circuitry. The primary circuit of Figure 3.2 and the secondary circuit of Figure 3.4 have been arranged in such a way as to increase the circuit's output, via the feed back line of wire 11 & 12, in much the same way that the self starting oscillator described in Chapter 1 supplies its own primary signal voltage. The secret, therefore, is to get the resonator to be self starting. After that, it should be only a matter of experimenting with component positioning and values to achieve the most efficient output.

The following drawing at Figure 3.7, shows a more detailed view of the Honeycomb layout. Note: that the second winding 8B has been laid directly over winding 8A with the same phase alignment. It may be that this second winding (8B) needs to be phase shifted (wound half a pitch out of radial alignment on (8A)) so that the windings mesh, rather than coincide. I am not sure if this will be needed, but it is an alternative option. If you do make a phase shifted winding, you will need twice as many pins to wind the two honeycombs.

MARK 1 HONEYCOMB COIL ASSEMBLY

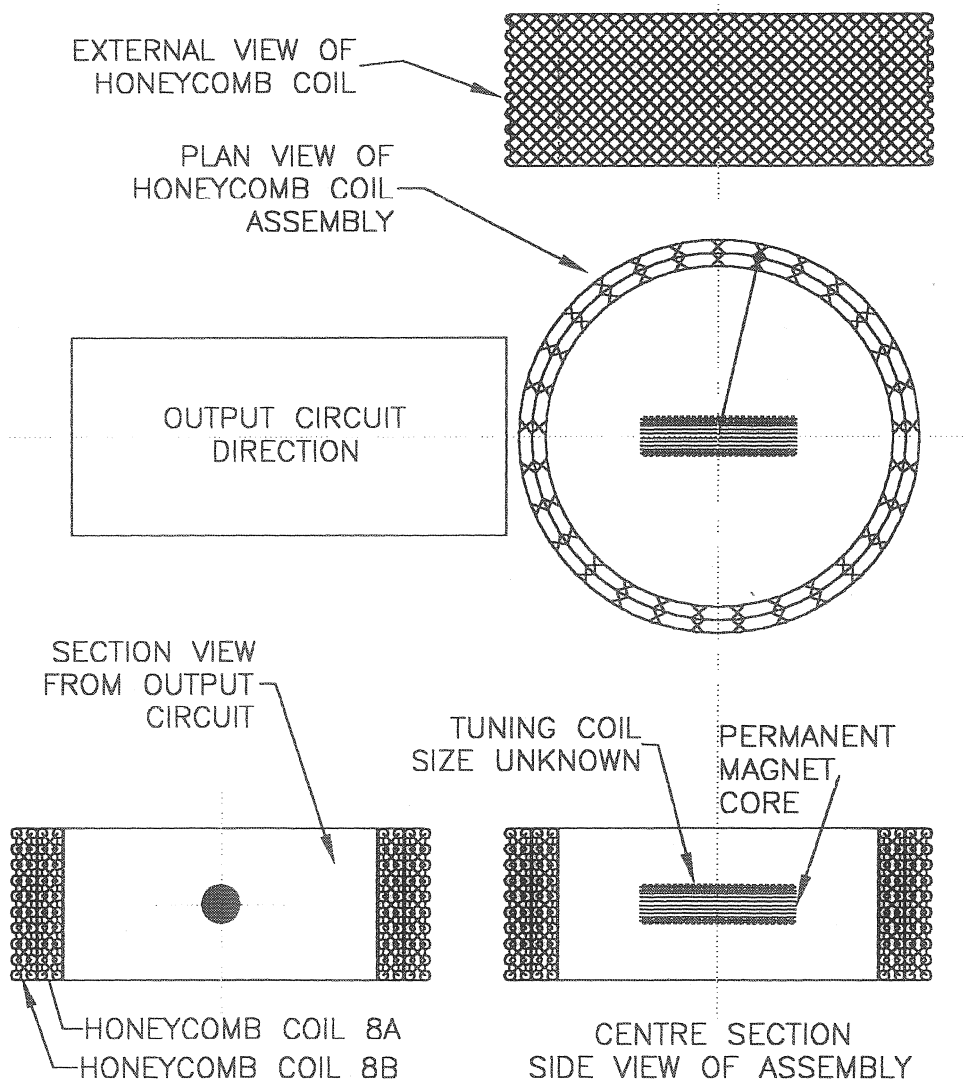

FIGURE 3.7

SUMMARY

For the construction of the Mark I Hendershot Solid State "Fuelless" Generator, the following components will be required:

(1) Soft Iron antenna (Statement 2 Part 2 App.D, states small metallic plate), I estimate approximately 3 inch long x 1 inch wide with non metallic mountings above coil (4).

(2) Flexible resonator/oscillator soft iron or steel strip (Statement 2 states magnetic material) - I estimate this to be about 3 inches long and 1/4 inch wide with a spring coupling and pivot anchor point (2A) connected to (1).

(3/4) (13/15) (14/16) & (22/23) 4 Bobbin wound coils on soft iron round cores. These are probably small actuator coils taken from an old telephone or door bell ringing circuit. The original drawing indicates that coil (22) is about the same size (diameter) as coils ((19) & (25), whilst coil (4) is only about 2/3rds the diameter. The size of coils (13 & 14) are not shown, but are probably a little smaller than coil (4). Coils (4) and (22) may possibly be wound from the primaries of transformers (18) & (27).

(18/19) & (25/27) These are the 2 small transformer assemblies. The TV vertical oscillator type used in the Mark III design may be suitable (E type transformers). Try using the secondary winding in tact, with the primary and centre lamination post removed) These transformers are around 2 ½ inches square, and both should be identical.

(6/7) This is the turning coil wound on a permanent round linear magnet (probably ferrite type). The winding of (6) is probably heavy gage wire close wound, about an inch long and 3/4in to 1in diameter.

(8A/8B) This is the honeycomb weave 2 coils. If the transformer frames are around 2 ½ inch square, then the honeycomb coils most probably have a diameter of 3 inches and stand approx. 1 to 2 inches high. Start with a Honeycomb square of around 1/4 in to 3/8 in.

The entire assembly should be mounted on non metallic chassis and provision made for the output terminals. The chassis should also allow for the relative electrical and physical adjustment of components. Avoid ferrous metals in chassis work.

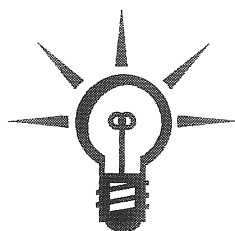

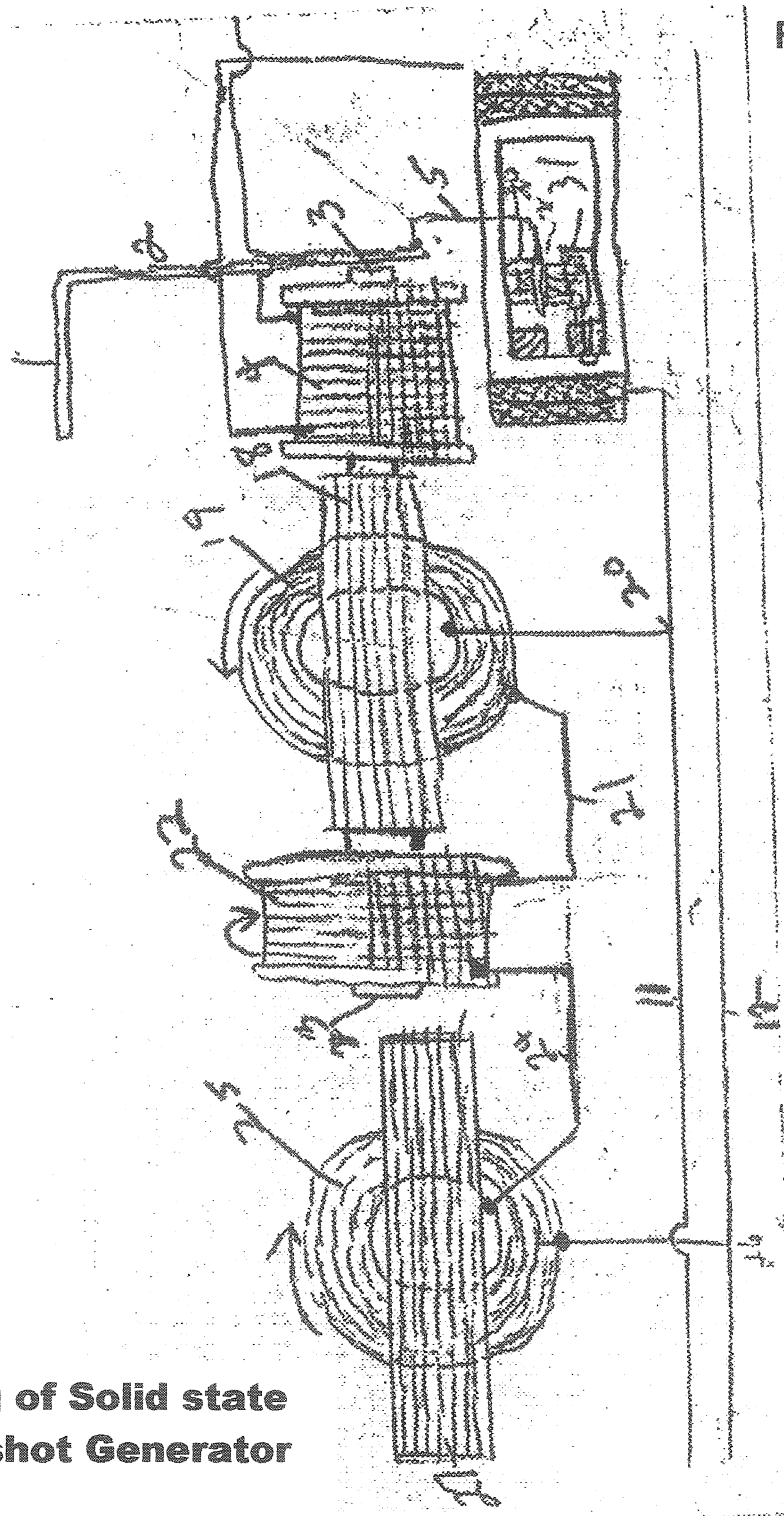

FIGURE 3.8

**Drawing of Solid state
Hendershot Generator
1920's**

courtesy of Mark Hendershot

HENDERSHOT'S MARK II SOLID STATE GENERATOR

It is claimed in Statement 20 Part 2 of Appendix D, that the Mark I device will only operate with its major horizontal axis aligned in the north & south direction of the earth's magnetic field. To overcome this objection, Hendershot states that he modified the original circuit of the Mark I device so that it will operate in any direction which its axis is placed

There is no explanation given in the text of the draft patent application of how these modifications were arrived at, nor is it explained what the functions of these new components are for. It may be assumed however, that they are somewhat a duplication of the resonator/oscillator circuit shown in Figures 3.2 & 3.3, set in a different plane and orientation, so that when the device is moved in any axis of alignment, at least one of the resonators (2) or (28) will be able to function, and therefore maintain an active output across (W11) and (W12).

Unfortunately, one of the original drawings that accompanied the draft patent application is missing. And, it is probably this drawing that contains the details of the main collector/receiver circuits. There is therefore no visual identified presentation that allows the accurate analysis of this new part of the circuit, other than the explanation in the draft and the almost undefinable hieroglyphics scribbled inside the coil assembly (8) on the original sketch provided. By a process of tenacity, logic and interpretation, I think I have now solved this problem, at least in the graphic sense, with a probable accuracy of around 75% to 80%.

In Statements 20 to 25, of Part 2 Appendix D, the modifications to Mark I, to update the device to the Mark II status have been explained. It states:

1. Wire (5) from Antenna (1), is connected to a small pivoted soft iron plate (28) (I assume this is almost identical to (2)); and from Claim 7, Part 3, it states "while permitting independent movements thereof (28)". The plate (or metal strip) is therefore a resonator/oscillator. This strip (28) is pivoted at one end to the centre of a brass end plate (30), which is in turn connected to Wire (5). *There is some confusion in this arrangement between Statement 21 Part 2 and Claim 7 Part 3.*

2. The resonator (28) is placed in the centre of a short coil (29) (Statement 21 Pt 2 & Claim 7 Pt 3), with the longitudinal axis of (28) parallel to the axis of coil (29), (Determined by analysis of an enlargement of the original drawing and the statement: resonator (28) is pivoted to the brass end plate).
3. Around the coil (29) is a circular soft iron Yoke (31) (Statement 21 Pt 2 & Claim 7 Pt 3), which holds the coil (29) in position.
4. Attached to the end of the Yoke (31), as a cylindrical extension to the Yoke (31) is a ring permanent magnet (33). It is assumed the soft iron yoke (31) and the ring magnet (33) are both the same inside diameter. From an analysis of the drawing (Figure 3.8), it appears the magnet is shorter in its length than in its diameter, whilst the iron yoke (31) is approx. the same length as its diameter. The ring magnet (33) also appears to have a larger outside diameter than the yoke (31).
5. On each end of the assembly are two brass circular end plates (30), which serve to close off the ends of the cylindrical apparatus. See Statement 21 Pt 2. *It is interesting to note that no mention is made of these end plates in any of the claims in Part 3.*
6. From Statement 21 Pt 2, it is stated the entire assembly is held together by a screw (bolt), which passes through and along one side of the cylindrical assembly to secure the end plates (30), the magnet (33) and the yoke (31) into a secure unit. Part of this screw (or bolt) can be seen in the bottom left hand corner of the coil assembly(8) in the original sketch (Fig. 3.8). Statement 21 does not specify that this bolt goes all the way through to the second brass plate, but if it doesn't, then there is nothing to secure the second brass end plate (30).
7. From Statement 25 Pt 2 and Claim 6 Pt 3 the axis of the cylindrical assembly is at right angles to the axis of coil assembly (8) and contained in the honeycomb coil assembly (8), so that the centre of coil (29) and the centre of coil assembly (8) coincide and is vertically below the axis of resonator (2). The longitudinal axis of the new cylindrical assembly and the axis of coil (4) are parallel. This means the modified assembly of Mark II has substantially the same orientation and position of the coil (6) & magnet (7) assembly of the Mark I design.

The above are the only modifications made to the Mark I design. On the following page as Figure 4.1, is my interpretation of these modifications for the Mark II design of the Hendershot Solid state Generator.

HENDERSHOT MARK II GENERATOR DETECTOR
/COLLECTOR HONEYCOMB COIL ASSEMBLY —
1927/28

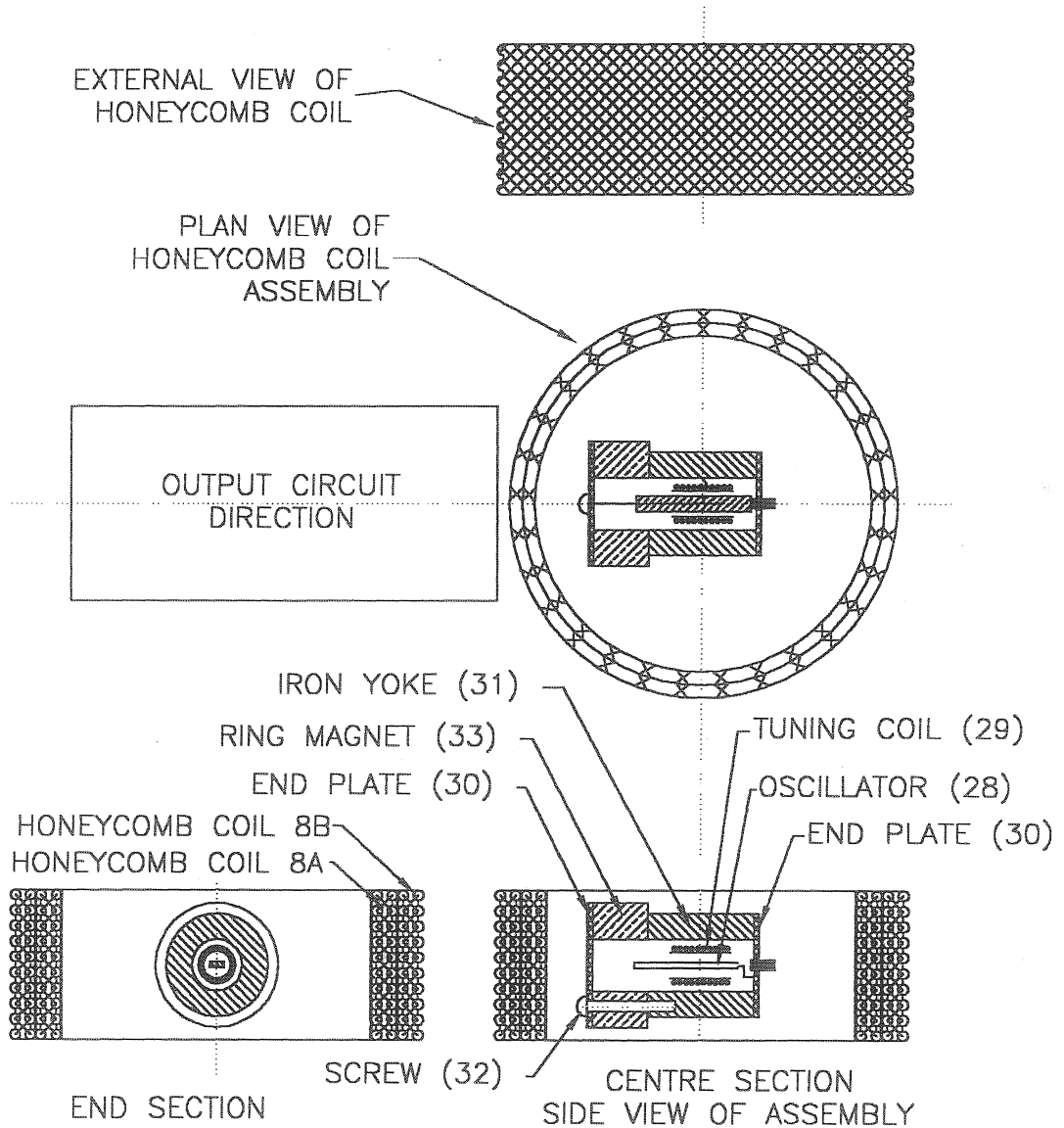

FIGURE 4.1

From the statements given in Part 2 and the claims in Part 3 of the draft patent transcribed at Appendix D, there are a number of different interpretations that can be made of the modifications for the Mark II design that can conform to the specifications given. All of the possible combinations that would satisfy the above requirements are graphically shown in the following drawings in Figure 4.2.

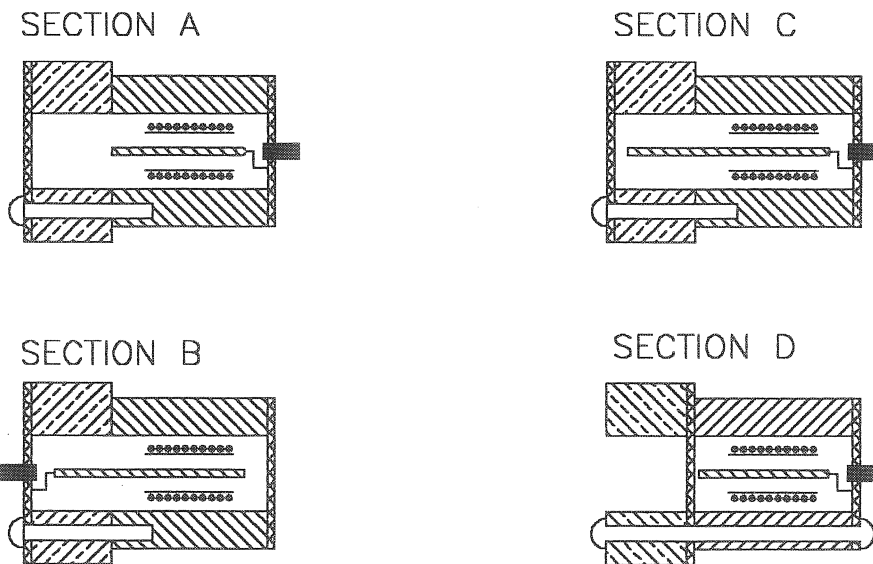

FIGURE 4.2

1. Because both end plates are labelled (30), and Statement 21 Pt 2, does not specify which of the two end plates the Resonator (28) is pivoted at, The resonator (28) can be pivoted from the right, as shown in (A), or pivoted from the left, as shown in (B). Claim 7 Pt 3, states however "means to electrically connect said extension (31) and member (28)". The claim specifically mentions Yoke (31), but does not mention the magnet (33). The claim also specifies an electrical connection, without any mention of a magnetic connection to Resonator (28). From this it may be inferred, the resonator should be pivoted to the Yoke end of the assembly as shown in (A).

By fitting the brass end plate to pivot the ferrous material of the resonator, he has isolated the resonator (28) from becoming permanently polar magnetic, yet at the same time providing an electrical connection to the yoke via the pivot connection in the brass end plate and the electrical connection to the antenna via wire (5).

2. No mention is made of how long the resonator (28) is. It could extend into the direct field of the magnet (33), as shown in (C), or it could be the same length as the iron yoke (31) as shown in (A). Each of these two arrangements could have a different electromagnetic effect on the resonator (28). From an enlargement of the original sketch, it appears the resonator is fairly short, and may therefore just be contained within the Yoke (31), as shown in (A) & (D).

3. Even though Statement 21 Pt 2, describes the brass plates (30), as *END* plates, it does not specify if these end plates are to enclose the entire cylindrical arrangement, as shown in (A)(B) & (C), or just the Yoke (31), as shown in (D), or just the Magnet (33) (not shown). In Statement 21 Pt 2, it states "Screw (32) serves to hold the yoke (31) to the magnet pole end " and claim 7 Pt 3, states "yoke (31) connected to one of the ends of said magnet (33) as an extension to (33)". These two specifications clearly state that there is no brass plate (30) between the two (33) & (31). The arrangement in (D) is therefore most unlikely. The only position then for the two end plates (30), must be to enclose the entire cylindrical arrangement at both ends.

4. Statement 21 Pt 2, also states "The screw (32) serves to hold the yoke (31) to the magnet pole (33)" Even though it is not stated that the screw or bolt (32) should extend through the entire device, as shown in (D), it is the only method a single bolt could be used to secure both end plates. A second connection would be necessary in the middle of the brass end plate (30) to secure the pivot and electrical connection to wire (5). Should the resonator be directly connected to the screw (32), then the resonator (being ferrous material), would become permanently magnetic and the use of the brass plates would not appear to have any purpose.

From the above analysis it should now be possible to determine the correct layout by experimental evaluation.

The following schematic in Figure 4.3 shows the modifications necessary for the Mark II design of the Hendershot Solid state Generator.

CIRCUIT No 4 - HENDERSHOT MARK II POWER GENERATOR

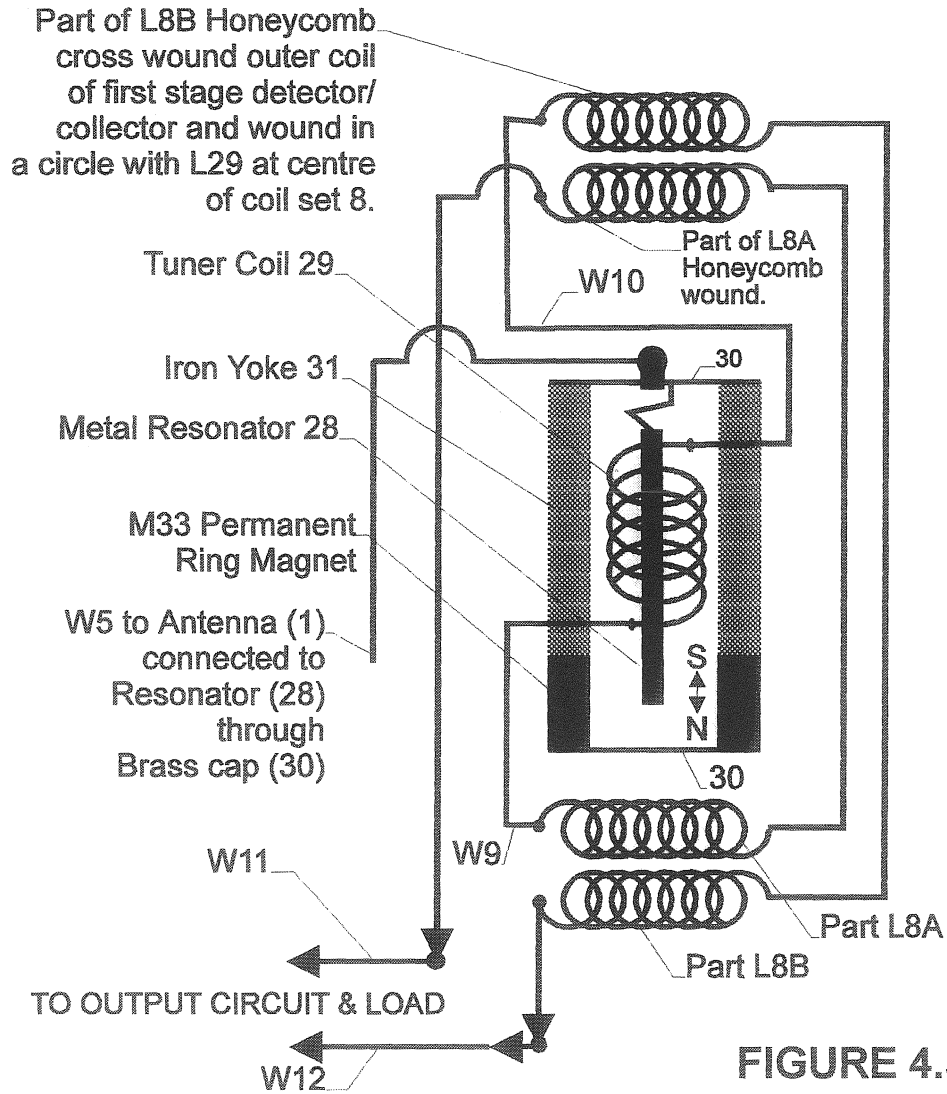

The entire schematic is shown in Figure 4.4 on the following page.

FULL CIRCUIT OF THE LESTER HENDERSHOT MARK II AC POWER GENERATOR DESIGNED LATE 1920'S

FIGURE 4.4

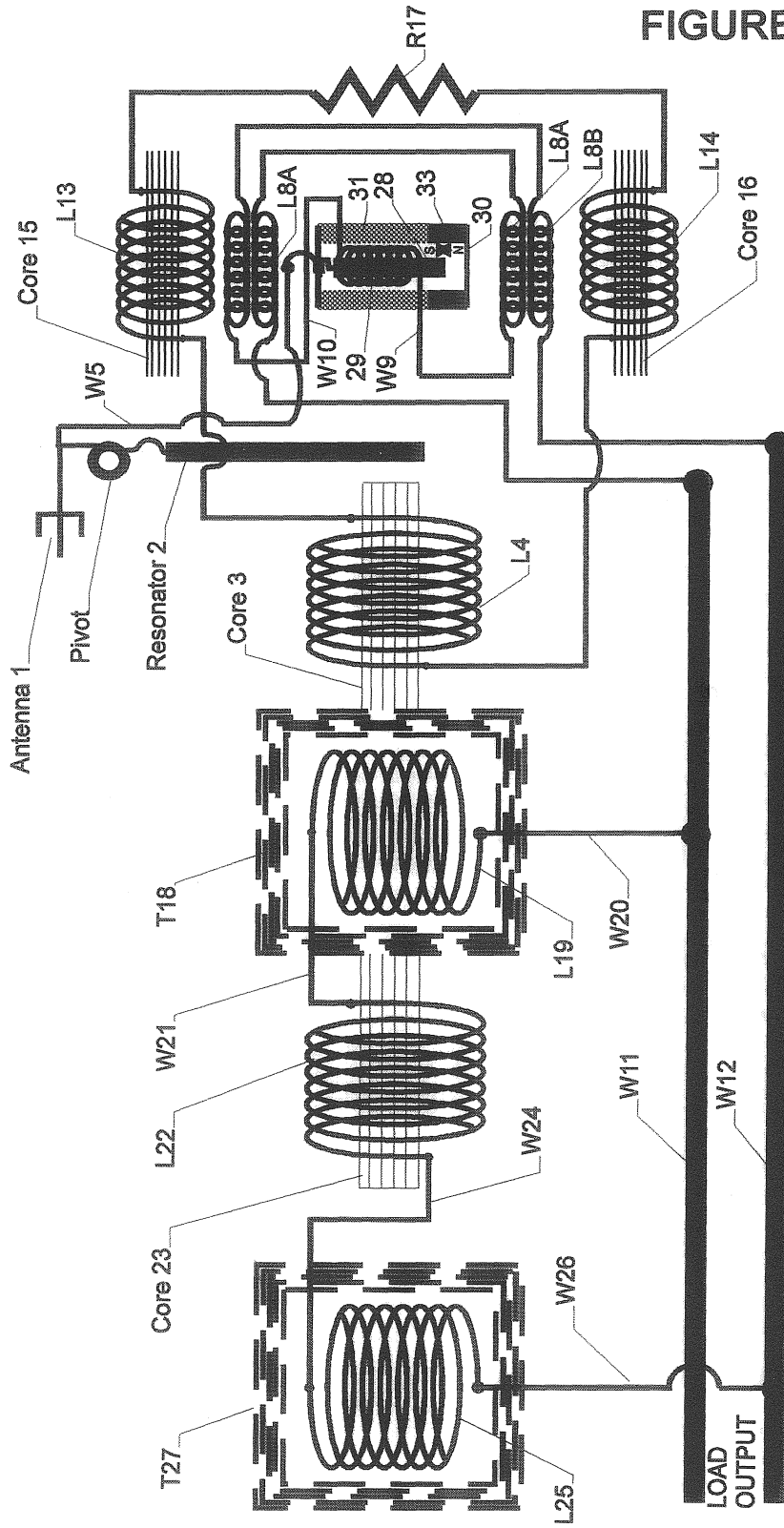

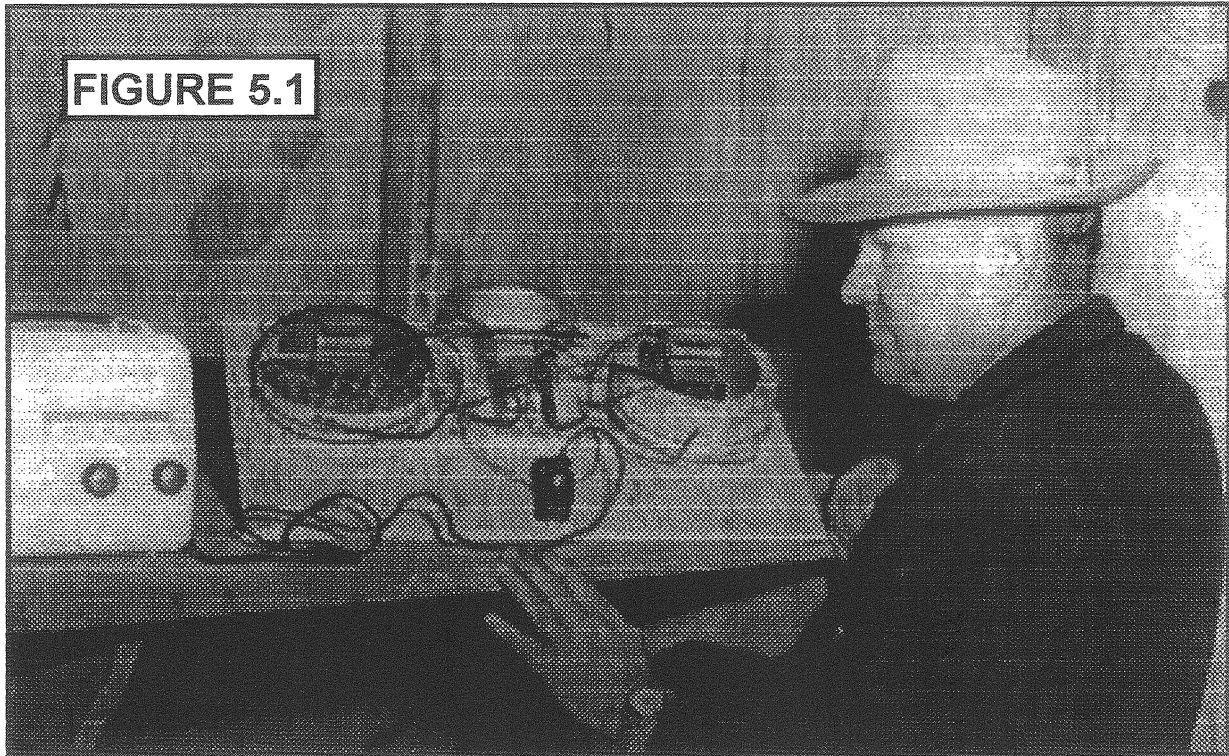
THE MARK III HENDERSHOT DEVICE

Lester J. Hendershot with his Mark IIIA "Fuelless" Generator
courtesy of Mark Hendershot

Lester Hendershot's supposed suicide on the 19th April 1961 passed without even a mention in the American press - that same press - that in 1928 had made him front page news across the nation. All, but a few of his closest associates, either had forgotten and dismissed the scientific miracles he had performed during the opening months of 1928 at Selfridge Airfield or had no knowledge Hendershot ever existed. It was left to such writers as: Charles Fort in his book "Wild Talents", Harold T. Wilkins in "Flying Saucers Uncensored", to F. D. Fleming in an article in Fate magazine in 1950, to Gaston Burrige, who personally interviewed Hendershot in 1956, and to Arthur C. Aho in his book "Energy Unlimited - A Case for Space" to keep the Hendershot mystery alive. But, most significantly of all, it was a gentleman named Ed Skilling, who gave the world the first authentic blue prints of a genuine solid state "free" energy generator that had been constructed and operated by Lester J. Hendershot. (See Appendix B).

Skilling had been engaged in 1958 to analyze and authenticate the device on behalf of a friend (with a doctorate in Science), who was intending to enter into a partnership with Hendershot to develop the device. In the pursuit of his commission, Skilling dismantled the device in order to identify the components and create an electrical schematic for the reconstruction and duplication of the generator. This original schematic I have reproduced as Figure 5.2 on the next page. Although Skilling was able to reassemble the device, as well as construct the duplicate, he was unable to get either working, and had to approach Hendershot for assistance. Even Hendershot was unable to achieve success until some months later. And it was this later demonstration that finally convinced Skilling, that the Hendershot generator was neither a hoax nor an exercise in telekinesis. On several occasions during the period 1958 to 1961, Skilling had witnessed a similar generator in Hendershot's home being operated by Hendershot's children without Hendershot's awareness.

Since Skilling's original article appeared in Round Robin in 1962, there has been probably many thousands of researchers around the world who have attempted to recreate the Mark III device, but alas, no one has ever proven publicly that they could produce useable output from the information provided. Even Mark Hendershot, with his inside knowledge of his father's inventions, has not been unable to achieve his father's success. Evidently, Lester Hendershot possessed some skill or knowledge of the device that was not passed on for posterity.

Since the days of René Descartes it has become a fundamental principle in scientific endeavour that all events in nature can be measured and formulated to allow the reproducible recreation of any such event. Although this premise may be fundamentally true, in reality, it is not always possible to carry out the necessary measurements and establish the right formulation that will guarantee repeatability. Two devices may appear to be geometrically identical in all respects, but there may be subtle differences, in the material used, in the construction, in the layout of components, or even in the environment in which they exist, that when tested for identical outcomes may produce entirely different results.

From the reports by Arthur Aho in his book "Energy Unlimited" and from the statements by Ed Skilling in his article, they claim that Hendershot could spend many hours fiddling with his Mark III device before he could achieve the desired result.

FIGURE 5.2

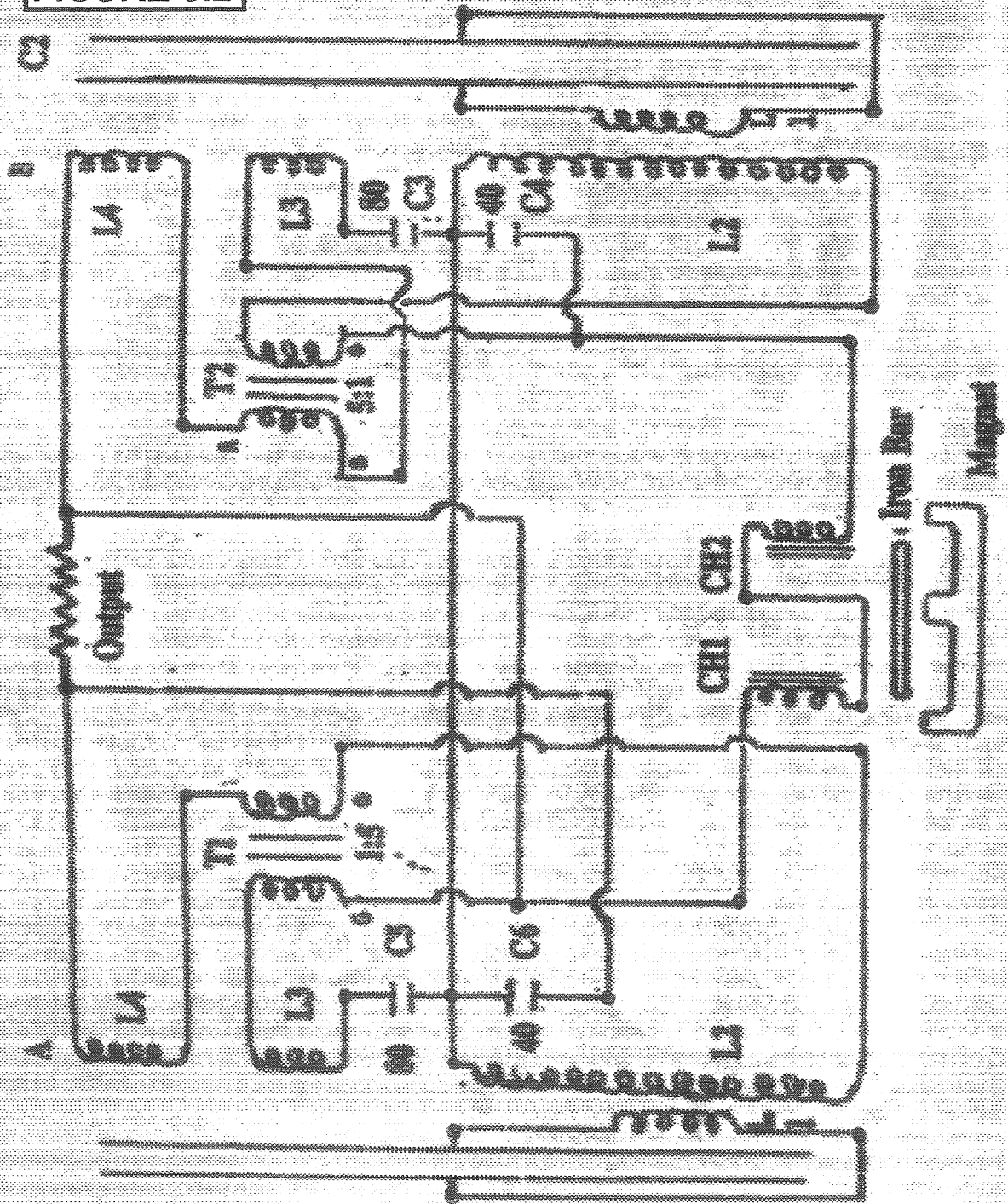

ED SKILLING'S ORIGINAL DRAWING OF MARK III CIRCUIT

According to Skilling, after the device had been constructed, he would probe various terminals of the circuit (probably the basket weave coils - Fig. 5.3[1]) with a length of insulated wire bared at both ends, until he achieved a resonance of the buzzer circuit ([7/8] of Fig 5.3) and the output light globe would start to glow. He would then adjust the gap between the metal resonator and the solenoid-magnet combination [9] until a full output was achieved to cause the light globe to glow with full brilliance. In one case, after some hours of exhaustive probing that failed to produce a satisfactory output, Hendershot found it necessary to rebuild the hand wound condensers forming the core of item 1 in Figure 5.3.

According to Aho, the hand wound condensers also could be a source of subtle problems. He states: "On one unit a slight unbalance of the home-made condenser was compensated for by squeezing a soft spot on one condenser. After Lester Hendershot had started the device by squeezing it, his hand tired, so he tuned it over to the author. A firm squeeze again started the output and you may be assured that it was a thrill to hold this pulsing condenser."

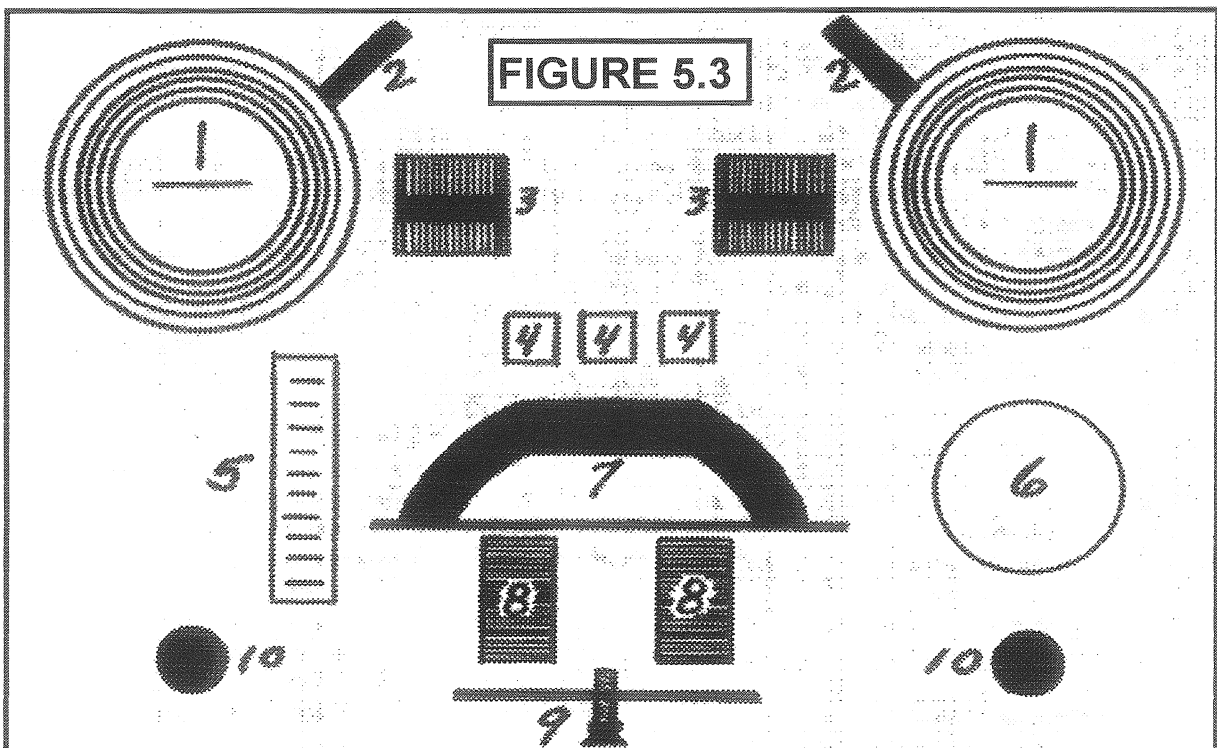

Mark III breadboard layout, drawn by Lester Hendershot
courtesy of Mark Hendershot

- 1. Hendershot Coil
- 2. Resonance Tuner
- 3. Step-up Transformer
- 4. Load Connector
- 5. Wiring Bank

- 6. Voltage Meter
- 7. Horseshoe Magnet
- 8. Electro Magnet
- 9. Adjustment Key
- 10. Capacitors

Figure 5.3 shows a breadboard layout of the components, believed drawn by Lester Hendershot. It will be noted that the components labelled (2) are called "Resonance Tuner". These two devices, are in fact "G" clamps, that Hendershot used to squeeze the Basket weave coil and condenser assemblies at various soft spots to get and keep the device operating. It is clear that this may be one of the fundamental problems in getting the device to work properly. Not only is it necessary to achieve a perfectly balanced capacitance, but the correct alignment and winding of the condensers are also critical if a satisfactory outcome is to be achieved. It maybe for this very reason, other experimenters have been unsuccessful in duplicating the Hendershot effect with the Mark III device. In the construction instructions given by Mark Hendershot and Skilling, they say to use paraffin wax to seal the basket weave and condenser assemblies in place. Should this be done prior to testing, then one may have difficulty in carrying out the necessary tensioning and alignment adjustments to get the thing working! On the other hand, there may be special ingredients in the paraffin wax that could be essential to its operation. I will discuss this a little later.

Two other points of concern, are those stated by Gaston Burrige in his article "The Hendershot Motor Riddle", in which he claims: "There is a relationship between the distance these coils are placed apart, the number of turns wound on them and the size of the wire". He also quotes Hendershot, "Sometimes, I wind on too many turns of wire. Then, the thing won't work. If I don't get on enough wire, the job soon burns out - sometimes in a few minutes, other times in a few hours. If all these materials are not in the proper portions the thing won't work at all. My biggest trouble though, is having them burn out. They never seem to last very long." This information, is probably the the most important of all because it demonstrate the the main critical elements of the construction in all of the Hendershot devices. It is interesting to note that if he puts on too much wire it won't work, but he doesn't make the same claim for too little. It should also be noted, that the placement of components are also important. Increasing or decreasing the distance between to basket weave coil assemblies may be the difference between success and failure. Putting the transformers inside the coils or outside may also make a difference.

It is blatantly obvious that these procedures are more of an art than a science, and therefore requires the artistic approach of unorthodoxy, tenacity, visionary observation, and persistent dedication, if success is to be achieved. A knowledge of component layout and materials used are only the starting point on a long and hard road to attaining those skills necessary to achieve that success.

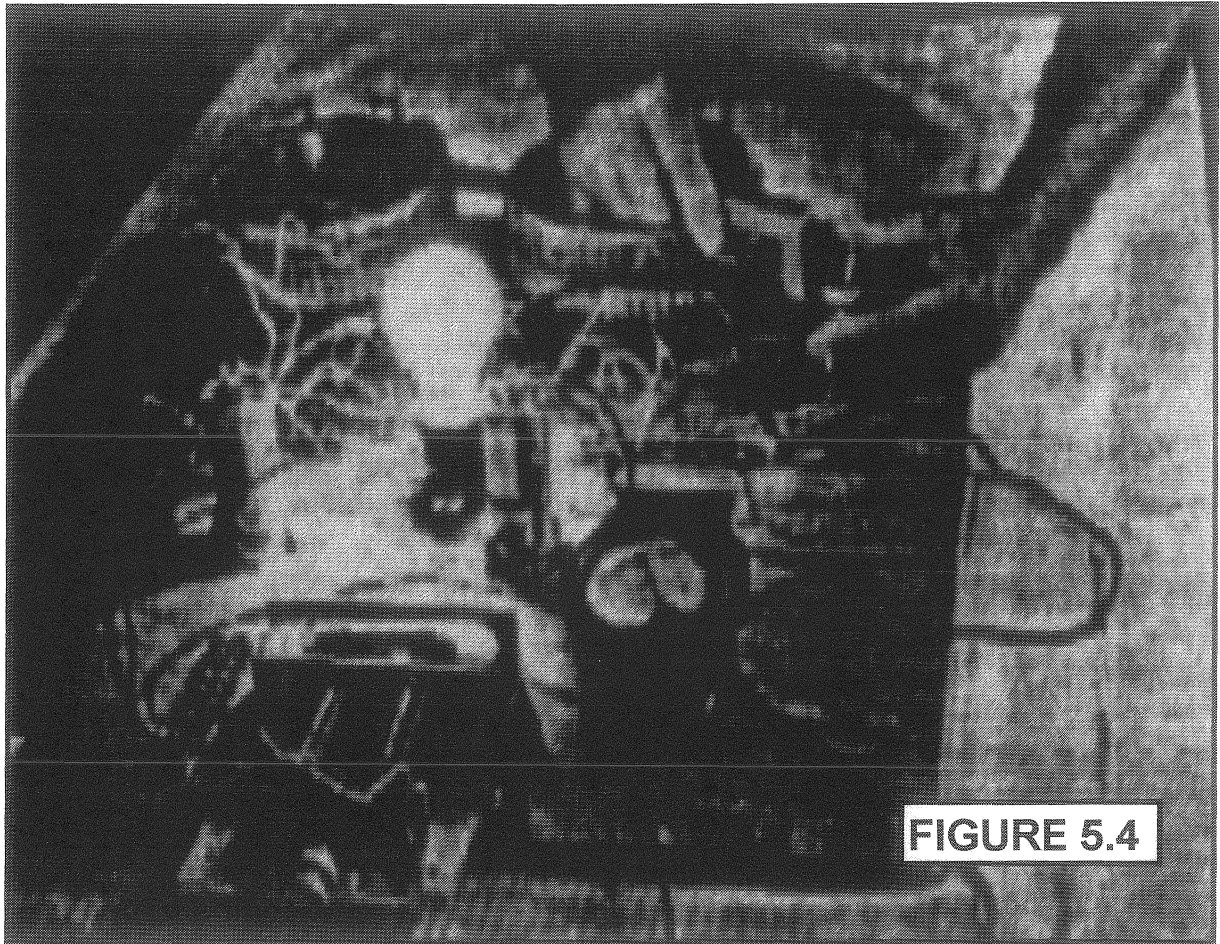

FIGURE 5.4

Mark IIIB Working "MagnaTronic" Hendershot Generator
courtesy of Mark Hendershot

The above photograph of Lester Hendershot operating a working Mark III type generator is probably the only one in existence that actually proves beyond a shadow of a doubt (by the obvious illumination of the light globe) that the device, if properly constructed and adjusted, does produce useable power output.

By the design of the magnet/solenoid layout in the photo and the use of a single Pyramid TM58 capacitor in each bank, it appears that this is the design developed around 1957, examined by Ed Skilling and schematically drawn by him in Figure 5.2, and also represented in Hendershot's own drawing of Figure 5.3, with the exception of a different magnet. However, as this has some different components from the device in Figure 5.1 (Mark IIIA), I have labelled this variation the Mark IIIB model.

Further examination of the photo in Figure 5.4, clearly shows the "G" Clamp being used by Lester Hendershot to adjust the relationship of the basket weave/capacitor assembly as referred to earlier in this chapter. On the basis of the statement made by Arthur Aho, that they used their fingers to effect this operation, it is assumed that the points of contact made by the "G" Clamp are insulated and do not form a bridging contact between the capacitor metal former and the outer coil windings, (Although this possibility is worth keeping in mind, as Skilling also stated that Hendershot short-circuited some of the contacts to start the device).

There is still one other variation of the Mark III design that has survived for posterity, and which I have included below as Figure 5.5. As can be seen, this device contains two banks of three condensers. I have labelled this device Mark IIIC.

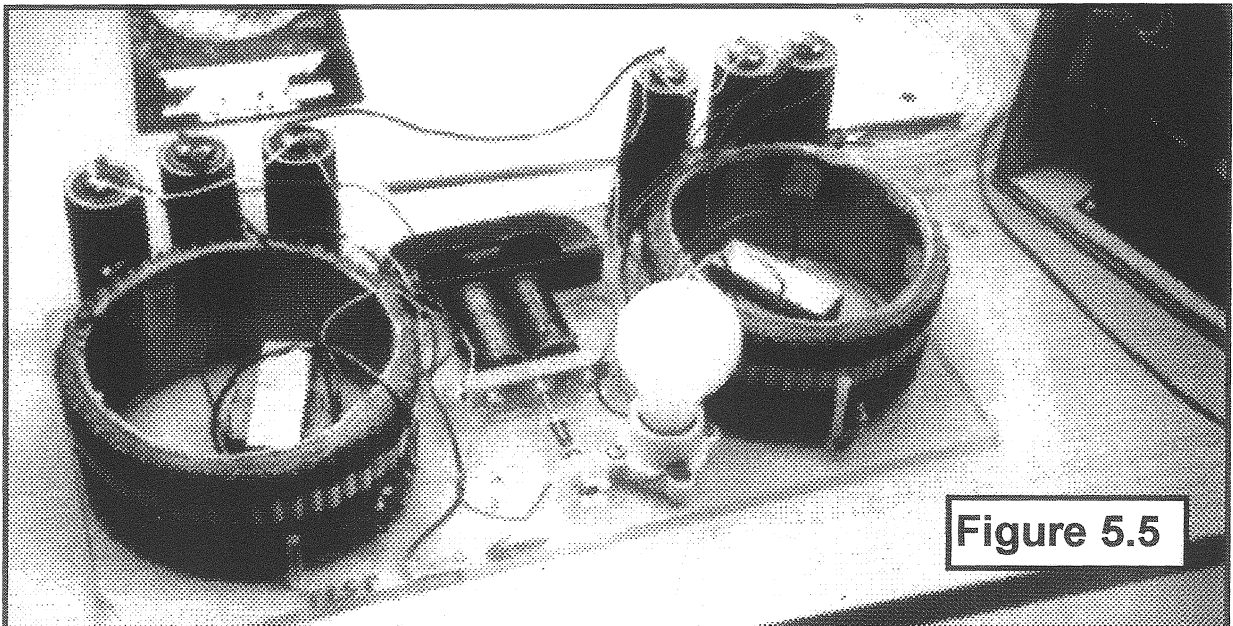
**Figure 5.5****Mark IIIC Hendershot Solid-state Power Generator**

The magnet used in this device, is from a radar magnetron and is the same magnet described by Ed Skilling. It is unknown if the TV vertical oscillator transformers are placed inside the coils for shielding, induction, or just to save space? It should be noted that the commercial condensers used in the Mark I model (Fig. 5.1) have only one in each bank and can be seen on top of the transformers inside the coils. These condensers are considerably smaller than used in the Mark II or the Mark III, and where probably changed to try and overcome the burn-out problem.

**The Mark IIIB
Hendershot
Generator**

Figure 5.6 is a slightly improved photo of the Mark IIIB design shown in Figure 5.4. Unfortunately it is slightly damaged and didn't show the second capacitor. Note that the transformers in this design are shown outside the basket weave coils.

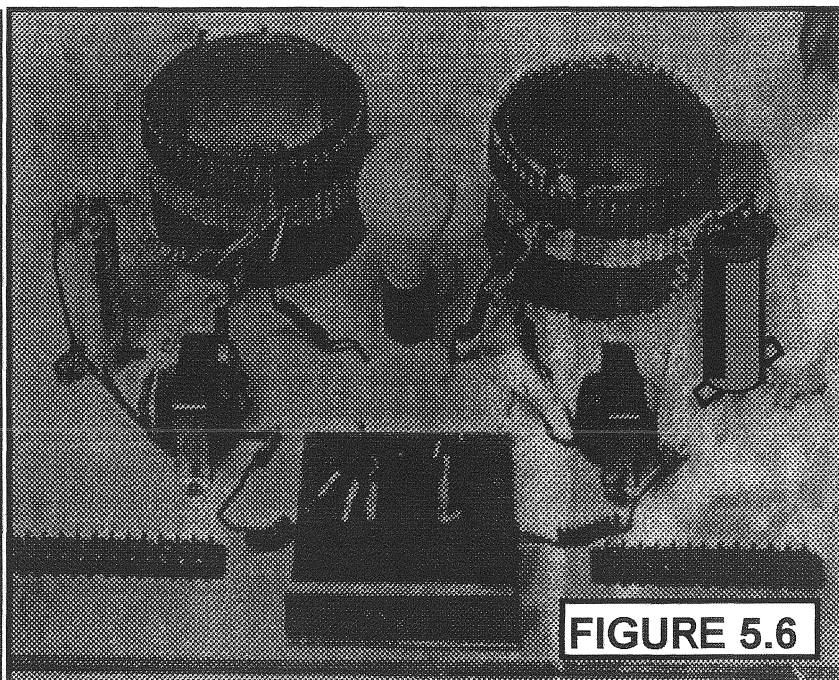

FIGURE 5.6

Although it is not clear at this point which Mark III device was the “chicken” and which was the “egg”, reasonably sound evaluations can be made on the historical timetable of recorded events.

When Gaston Burrige visited Hendershot in 1955/56, Hendershot was experimenting with “Pancake” basket weave coils and had also added condensers and standard transformers to the design.

In 1958 when Ed Skilling worked with Hendershot, his device was now using the cylindrical basket weave coils with a standard TM58 included in both banks.

In 1959/60's when Arthur Aho worked with him, the design had changed again to the three condenser design on each bank. Even though Aho did not include a circuit diagram in his book, Edward O'Brian, a Patent Attorney from Huntington Beach, California, (See Appendix B) visited Aho in Angeles County after Hendershot's death, and prepared circuit diagrams of the Aho device which is shown at Figure 5.16. Just before his death, Hendershot entrusted his latest Mark III device to a local printer whom he had befriended to store the working Hendershot device because he feared for its safety. This printer took photos of this model and it is believed the one shown at Figure 5.5 is one of these photos. I have other photocopies that are too bad to print of the same device taken in the printer's garage.

From the age of Lester Hendershot in the photo in Figure 5.1, he is probably in his mid 50's. The photograph was therefore most probably taken in the mid to later 1950's. It may be assumed from this that the device shown was also his latest innovation and constructed after Burridge's visit.

From the foregoing evaluation a clear picture now emerges. The device shown in Figure 5.1 (Mark IIIA) was probably invented in the early 1950's. The Mark IIIB was an improvement and probably developed late 1956 to early 1957. The Mark IIIC is undoubtedly his last device before he died.

What developments he achieved between 1930 and 1955 is not in the public domain. But in 1956 he moved with his family to Mexico to work for the Mexican government for a few months on his device, and it was probably there that he developed the Mark IIIB design. The Mark IIIC design was probably developed for Lloyd Cannon (See Appendix C), in 1960. His high profile involvement with Mr Cannon, may have resulted in Hendershot's untimely demise.

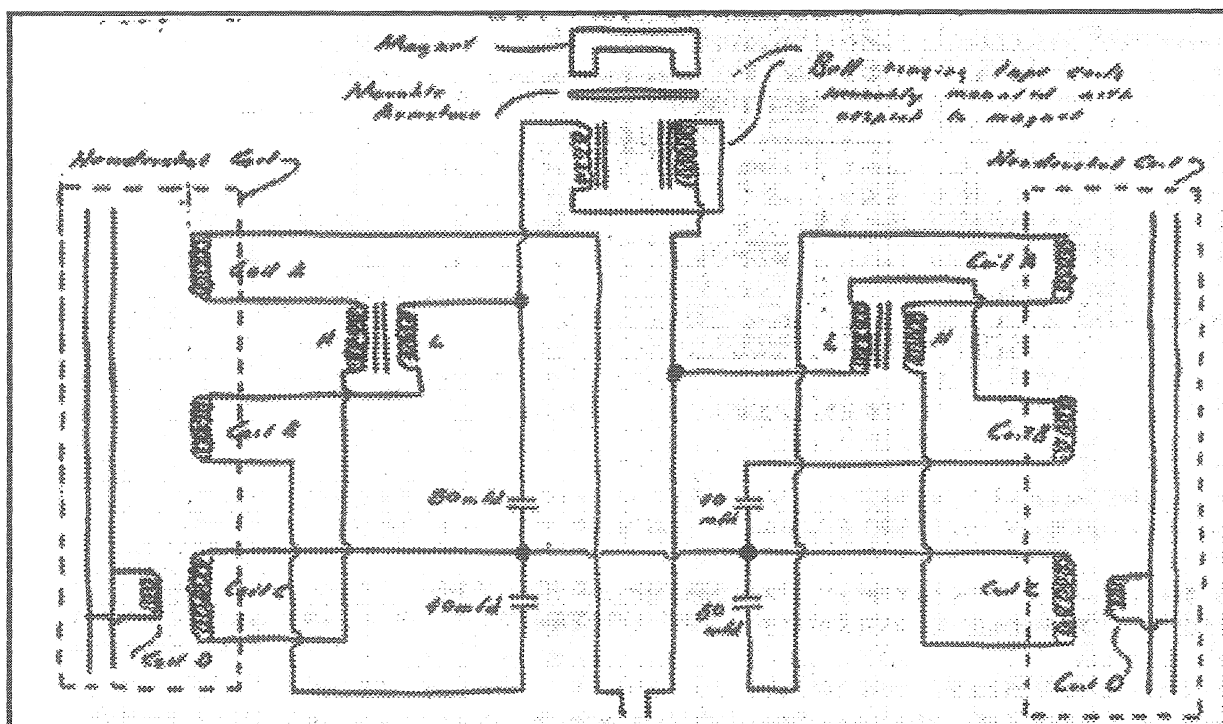
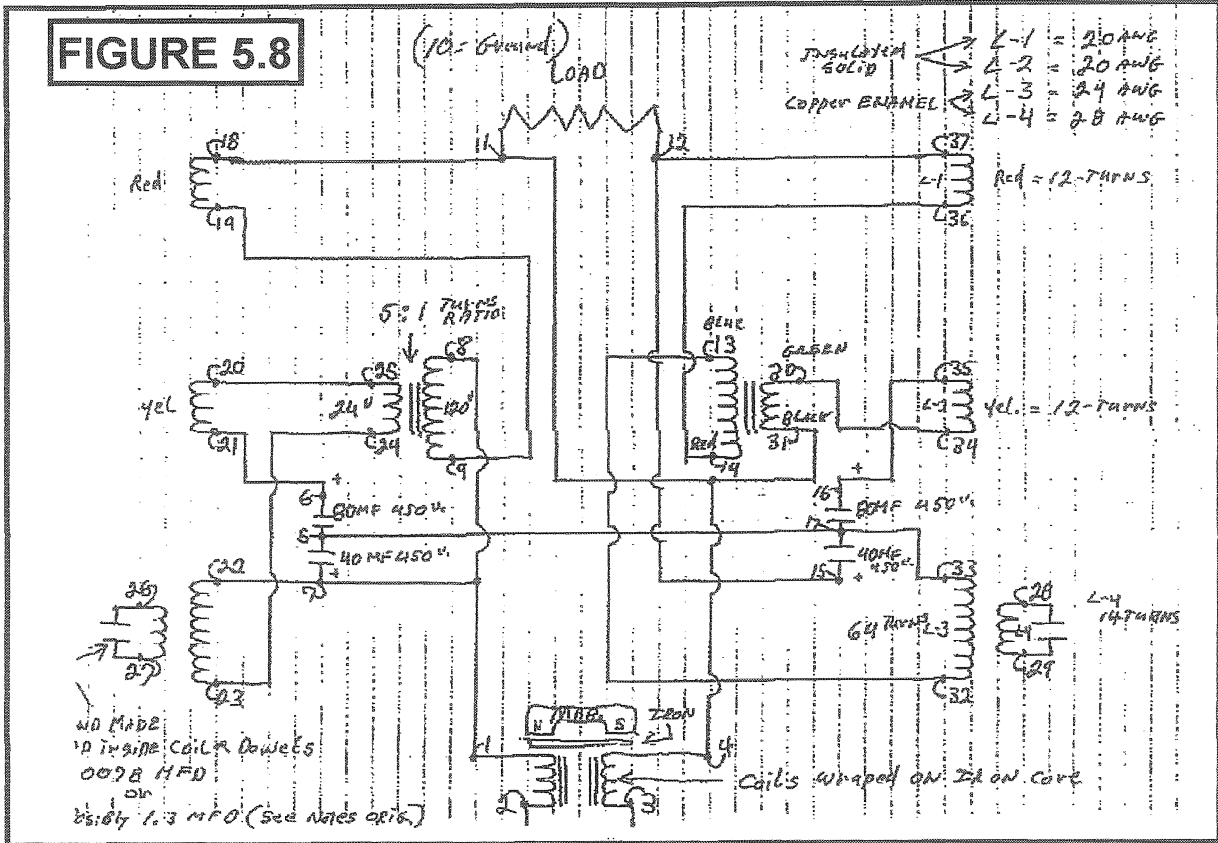

FIGURE 5.7 - The Arthur Aho version of the Mark IIIB Circuit Diagram Hendershot Generator
drawn by Edward O'Brian in 1963



**Mark IIIB Circuit Diagram from Documents of
Lester Hendershot's
courtesy of Mark Hendershot**

The above circuit diagram was released by Mark Hendershot as being part of his father's papers. From a comparison of the hand writing in Figure 2.3, it is possible that Lester Hendershot drew this circuit himself after studying Skilling drawing. It is too close to Skilling's layout to have been drawn before meeting Skilling.

In addition to the different choices of connections offered by Skilling, Aho and Mark Hendershot for the Mark IIIB design, Skilling also points out that C6 (half of TR58) in Fig. 5.2 has its plus terminal connected to one side of the output load and places an electrolytic capacitor in an AC circuit. Polarised capacitors are not designed for this type of connection as they would soon overheat and be destroyed when subjected to AC loads. This is exactly what happened when the circuit was energised by Hendershot. Skilling suggests to changing the connection the same as C4, but I can't see how this can be done without disturbing other parts of the circuit.

On the following two pages I have redrawn the previous three circuits of Skilling, Aho and the one supplied by Mark Hendershot as being from his father's papers. In addition, I have also included as Figure 5.10, a reconstruction of a circuit diagram that was included in the re-edited version of Skilling's article (See Appendix B), in "Energy Unlimited #13".

It is interesting to note that Skilling included this circuit diagram to show the results of the various tests he conducted on his version of the Mark IIIB design. But, it will be observed, that the original circuit of Skilling's, re-created at Figure 5.9, (also appearing in the same article), and this second schematic re-created at Figure 5.10, do not correspond. It is strange that no mention is made of this by Skilling when he re-hashed the article for "Energy Unlimited". It is clear that he could not have carried out the working tests on the apparatus until after October 26th, 1958, when Hendershot finally got it going. It is my belief, Hendershot made some changes in the circuitry after it was reconstructed by Skilling and returned to Hendershot in an inoperative condition. These changes have been reflected in the second schematic (Fig 5.10), that Skilling did not include in his original article in "Round Robin". Alternatively, Skilling may have made some mistakes in copying the original layout, and used the second schematic to correct these errors. I would therefore tend to disregard the wiring arrangements in Figure 5.2 (and redrawn in Figure 5.9) as it does not appear to have a good balanced layout. The schematic in Figure 5.10, is far more symmetrical across the two halves of the device, but still lacks some refinements in the feed back loop, to prevent C6 from burning out.

I have included the following redrawn versions because of the poor quality of the previous drawings and the difficulty of trying to compare and analyse the circuit differences. By providing a uniform format for the layout of components, the job of comparing the circuit differences is considerably simplified. It will also make it easier for researchers who may wish to vary the circuit wiring for testing the various designs. In my reconstructions, I use Skilling's system of identification (Note: Hendershot & O'Brian use different coil identifications).

The results of Skilling's tests on the circuit at Figure 5.10 are as follows:

L4 35 μ hy D-Q = 0.8 Open. DC 0.2 ohms
 L3 30 μ hy
 L2 72 μ hy D-Q = 1.2 Open In series 76 μ hy DC 3 ohms
 L1 0.12 mhy DC 1.6 ohms
 T1 & T2 *Low side* 65 mhy D-Q = 0.6
 T1 & T2 *High Side* 60 mhy D-Q = 0.3 Dc 400 ohms Open
 C5 40mfd C6 40mfd(?) 35 VAC C4 40mfd(?) 70VAC
 C3 40mfd 54 VAC (See Figure 5.10 for other data)

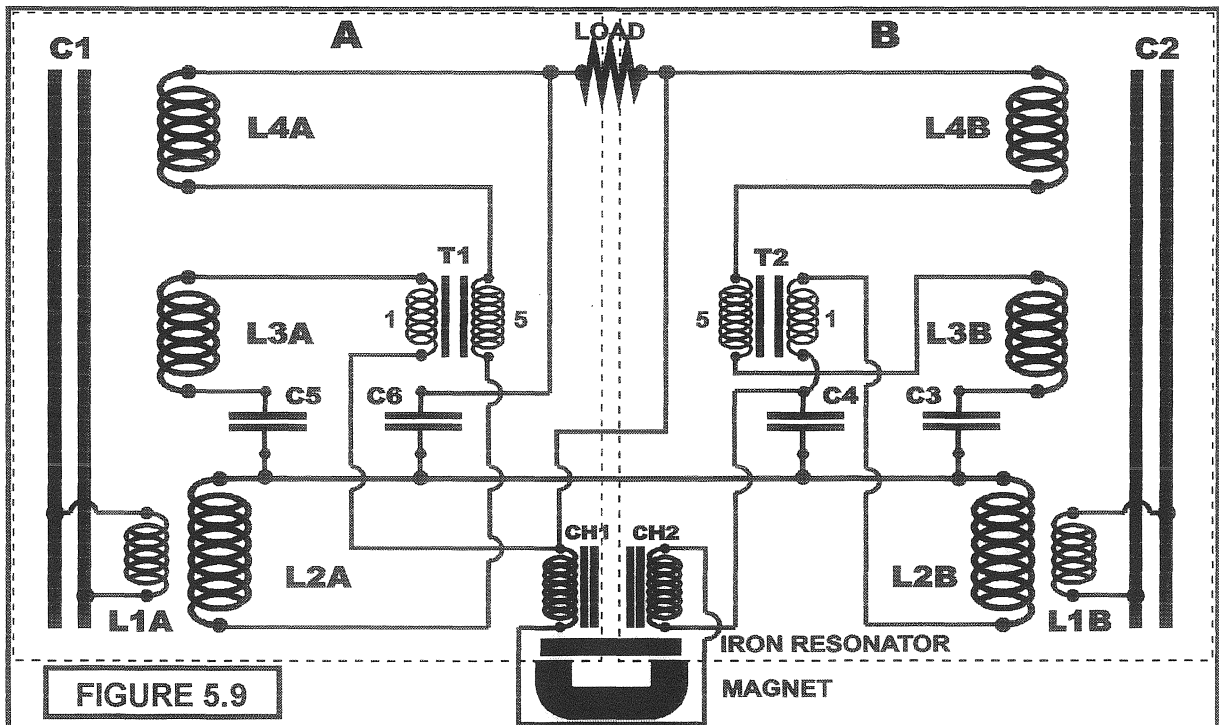

FIGURE 5.9

Redrawn Original Skilling Circuit from Figure 5.2

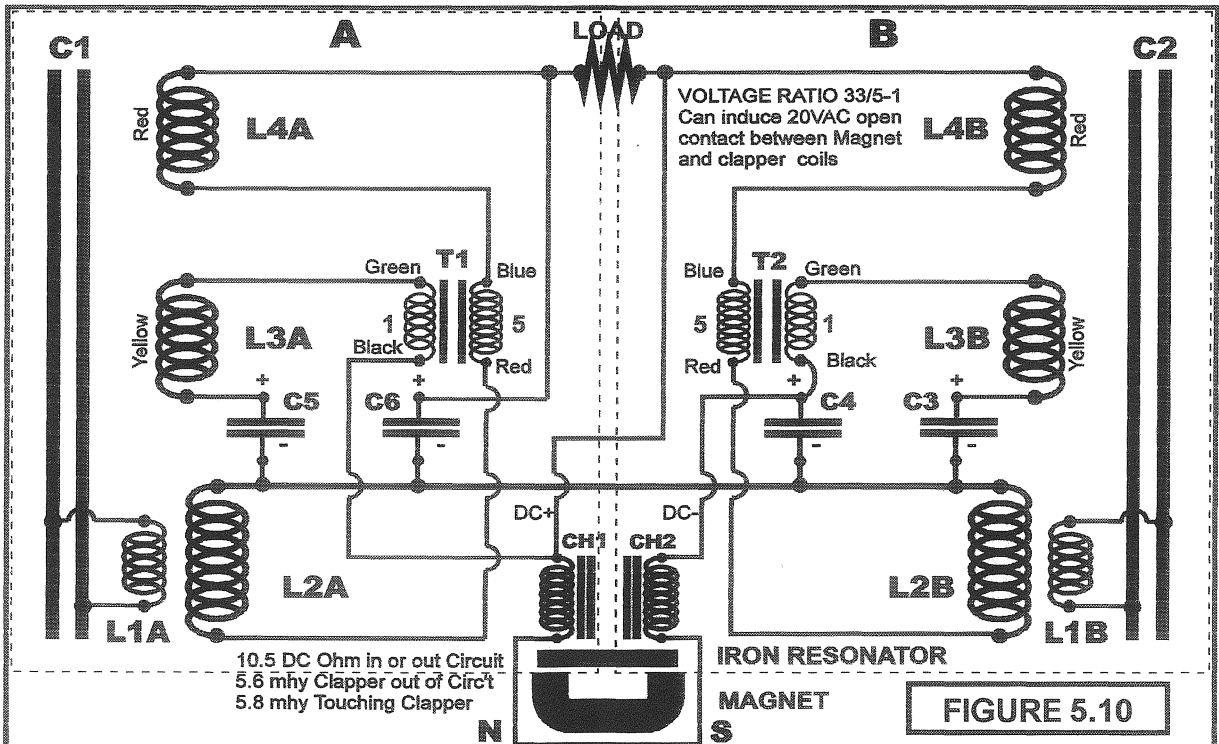

FIGURE 5.10

Redrawn Skilling Circuit No 2 from "Energy Unlimited"

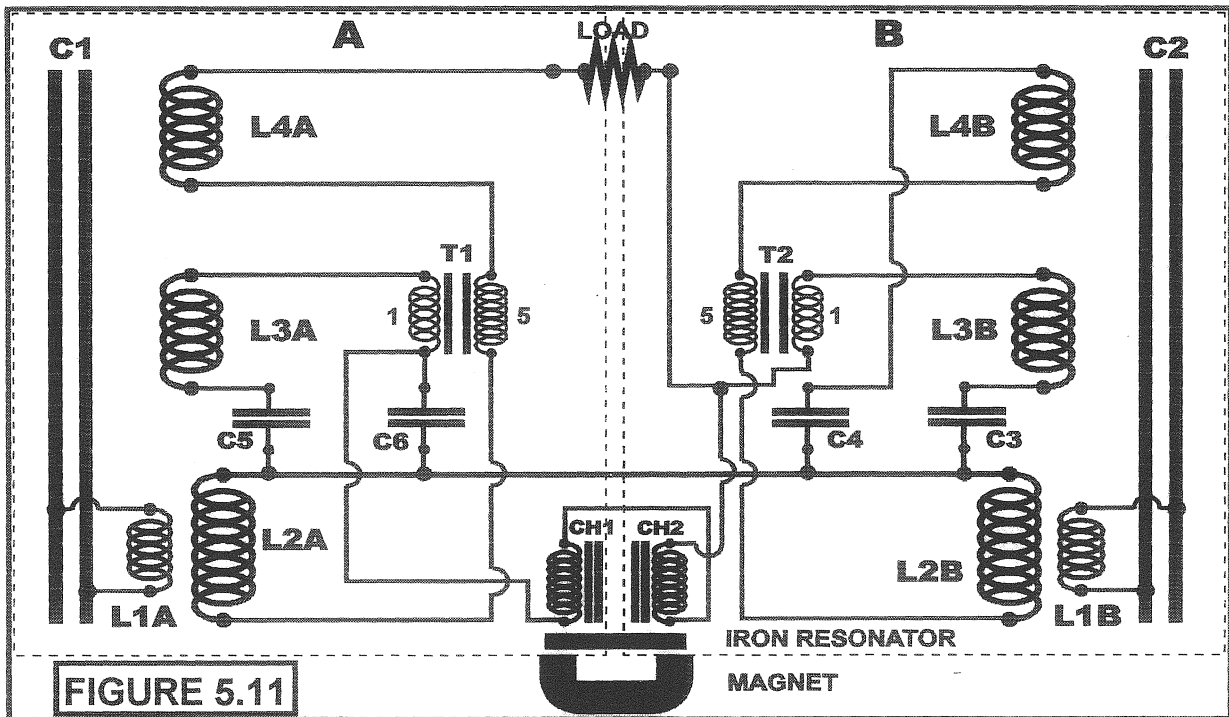

FIGURE 5.11

Redrawn Aho Circuit from Figure 5.7

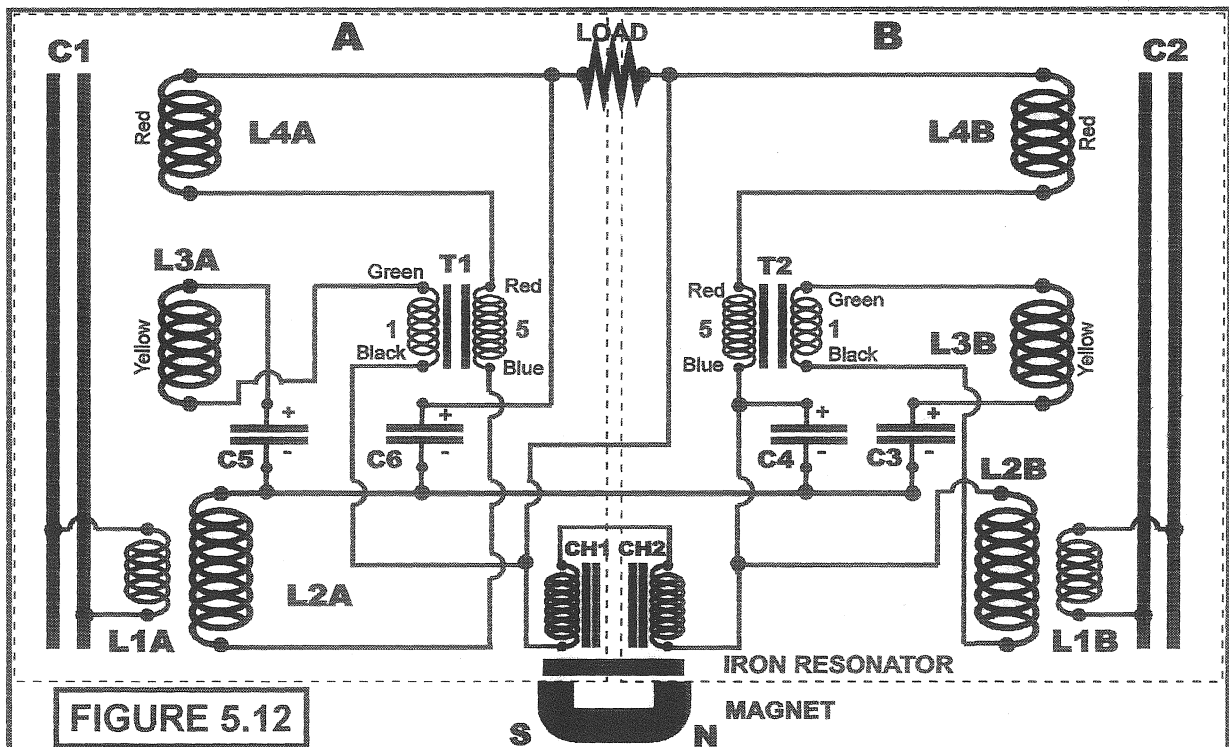

FIGURE 5.12

Redrawn Lester Hendershot Circuit from Figure 5.8

The tests done by Skilling on Figure 5.10 also provide a couple of anomalies. In his reprint of his original drawing (Figure 5.2) in "Energy Unlimited" he included the values of C3 & C5= 80 mfd whilst C4 & C6 = 40 mfd, as represented in Hendershot's drawing (Figure 5.8). Yet, in the test results of Figure 5.10, Skilling indicates only 40 mfd for all four capacitors.

In Mark Hendershot's remarks in Appendix C, he indicates that he used "non polarised" capacitors. Yet, in Skilling's test circuit of Figure 5.10 and Hendershot's drawing of Figure 5.8, all of these capacitors are shown as polarised.

In 1996, when Mark Hendershot released the update to his paper "From The Archives of Lester Hendershot", he included two additional circuits that he had drawn. He didn't state if he had used either of these to try and reconstruct his father's Mark IIIB design. The first drawing I have included in Figure 5.13 below, and reconstructed both on the next page using my standard format, which is a mirror image. It is interesting to note in this circuit, Mark does not connect any of the capacitors to the load feed back line, but instead connects the load on the "A" side to Coil L4A and the secondary of T1, whilst on the other side "B" he connects the load to L4B, the bobbin solenoid coil CH1 and the primary of T1, (See Figure 5.14).

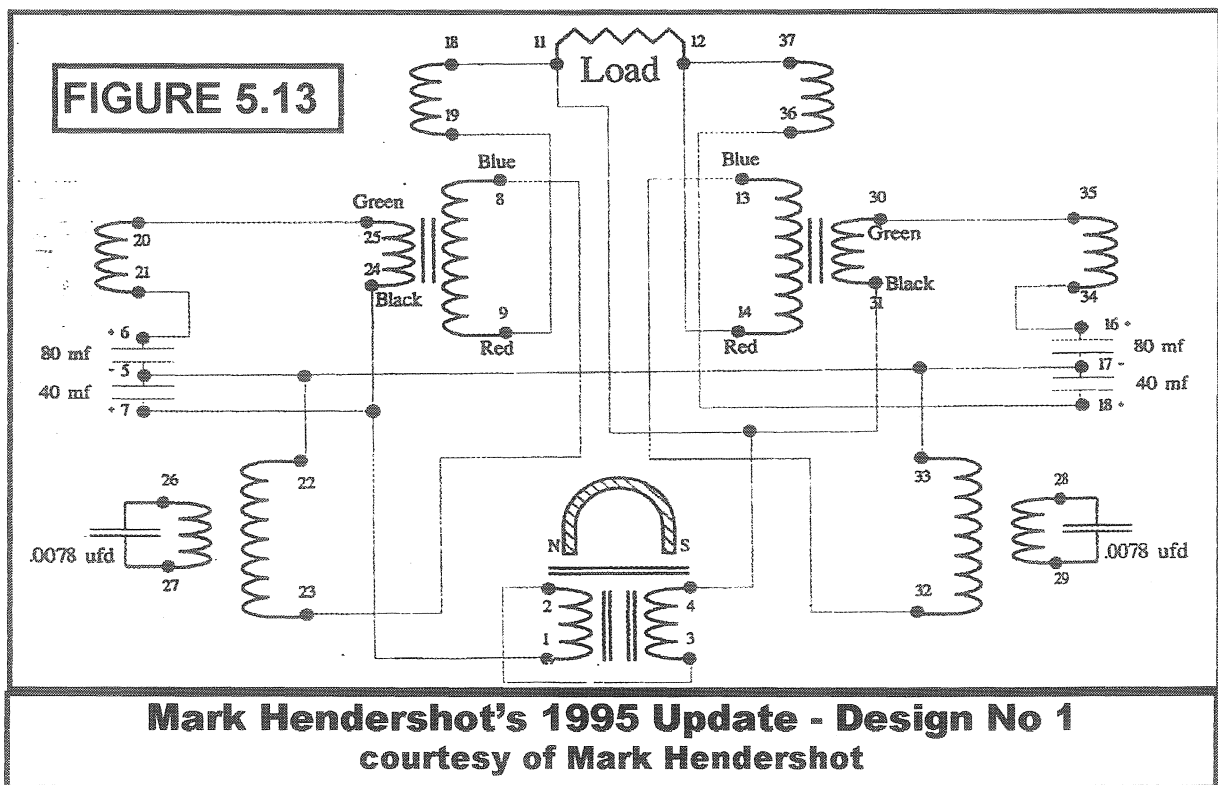

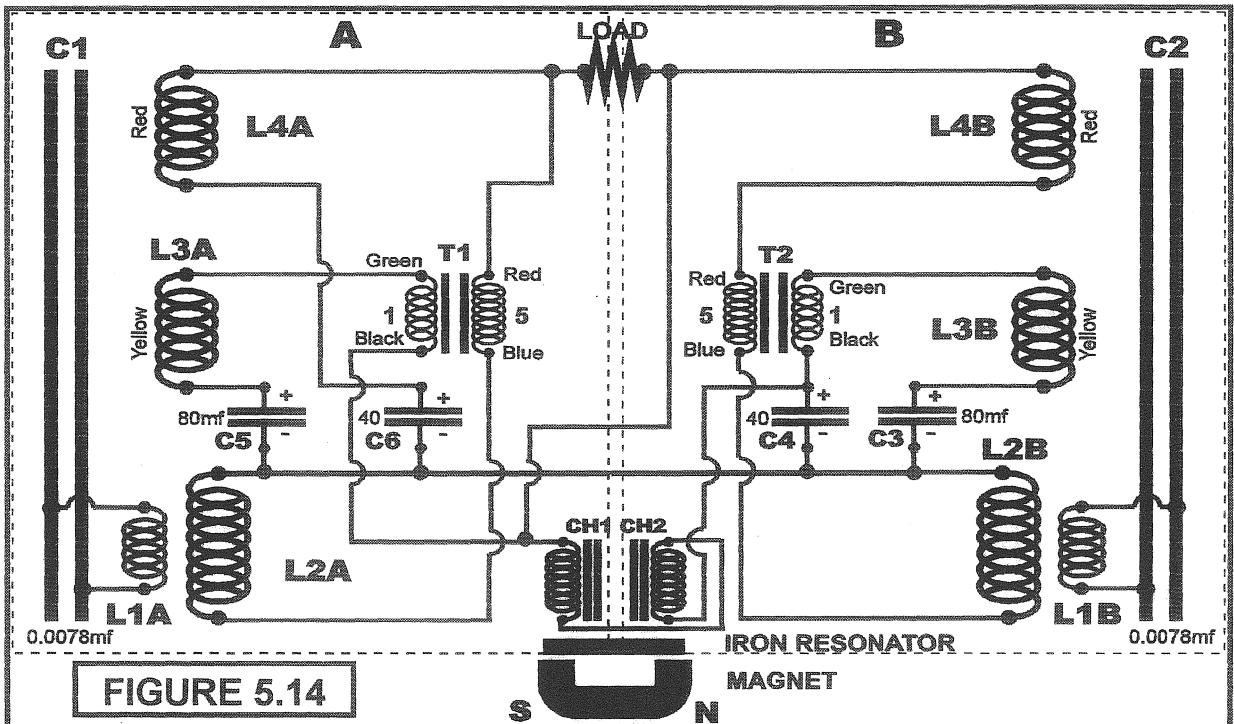

FIGURE 5.14

Mark Hendershot's 1995 Update Mark IIIB Design No 1

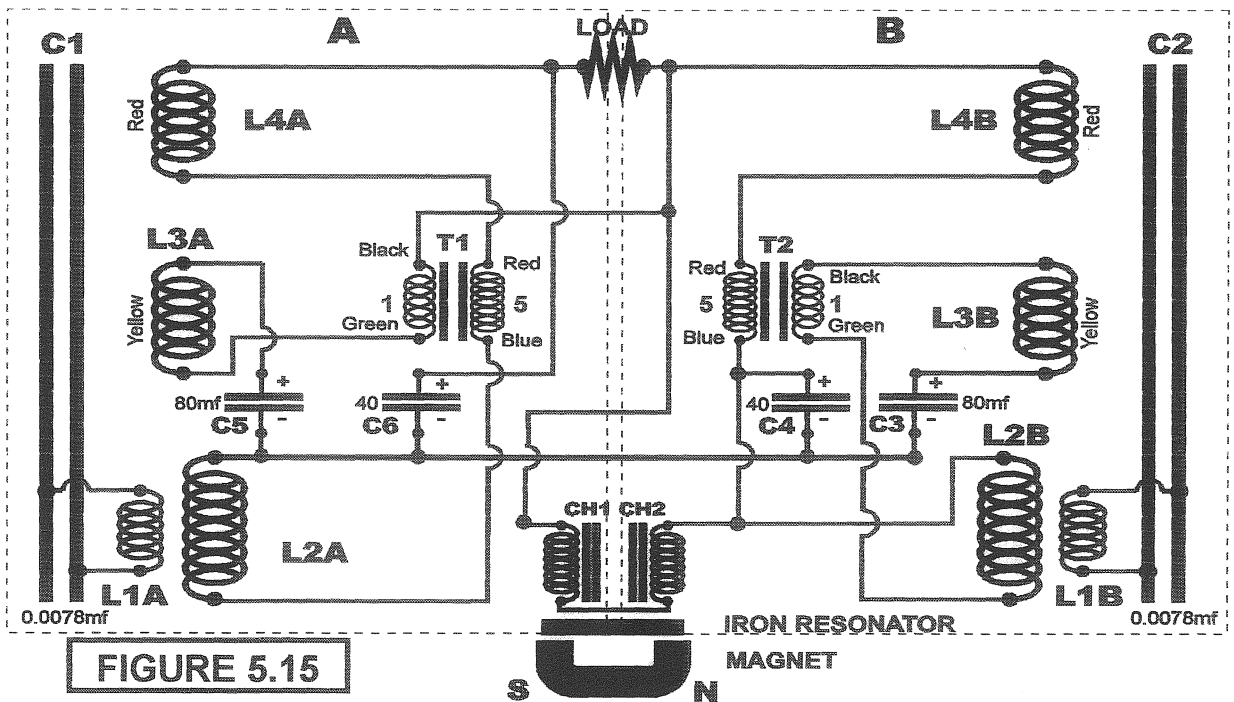

FIGURE 5.15

Mark Hendershot's Circuit No 2 Mark IIIB

The Mark IIIC Design

The circuit diagram shown below at Figure 5.16 is the circuit traced out by Edward O'Brian at Arthur Aho's home in 1963 from the device Aho constructed under the direction of Lester Hendershot just before he died and still had in his possession (inoperative) at the time.

A cursory check of the circuit will reveal it is a considerable departure from the circuits used in the Mark IIIB design. It not only includes three independent capacitors (450 working volts) instead of one, but possibly has eliminated the problem of burn out. However, O'Brian has made a bad error in tracing out the circuit, because the primary of T2 has been directly short-circuited. If the device worked at all using this circuit, then it is clear that some of the connections made and components used were unnecessary. As Aho states that this device worked, and there is no reason for him to lie, then it is probable that the circuit has not been correctly transcribed.

As a capacitive/ inductive design, the "B" bank of the circuit layout in Figure 5.16 seems electrically illogical. Coils and capacitors generally have wiring layouts either in series or parallel, and bank "B" is a "hotchpotch", with little of the "B" bank of the circuit showing the normal electrical resonant arrangements, (See Figure 5.17 and 5.18). Note: Wire "W", in Fig. 5.16 is used for stroking some part of the circuit to get it going by using the human body as an antenna. The wire is then connected across that point.(?)

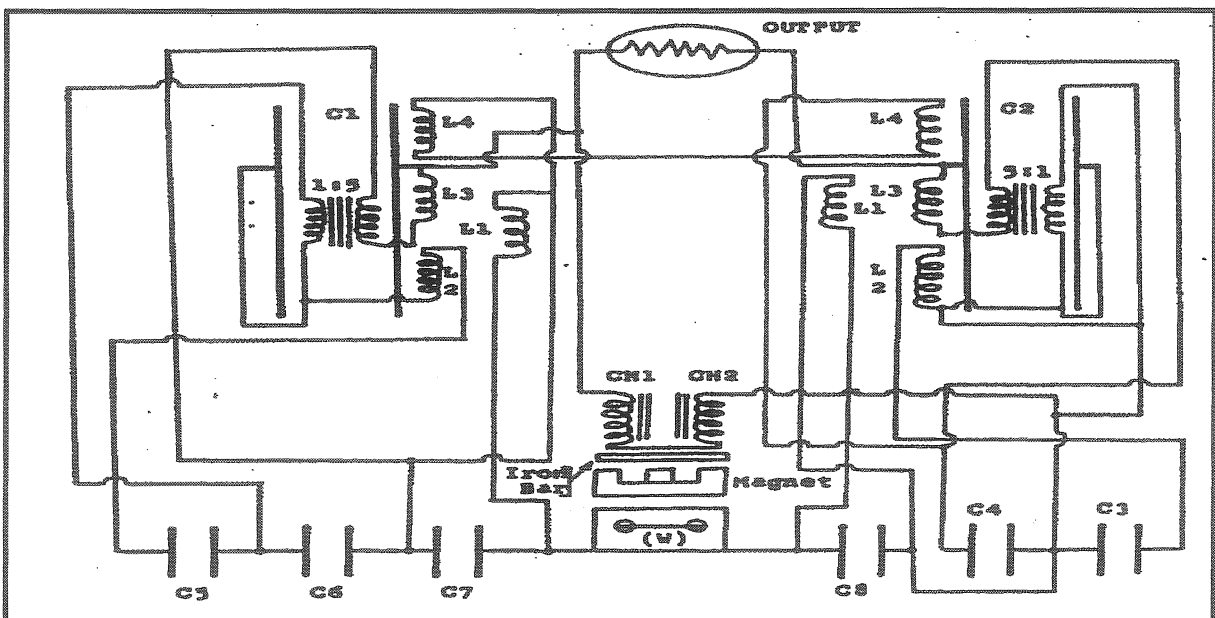

FIGURE 5.16 This layout, of the Aho Mark IIIC device, was drawn by Edward O'Brian, a Patent Attorney from California, in 1963.

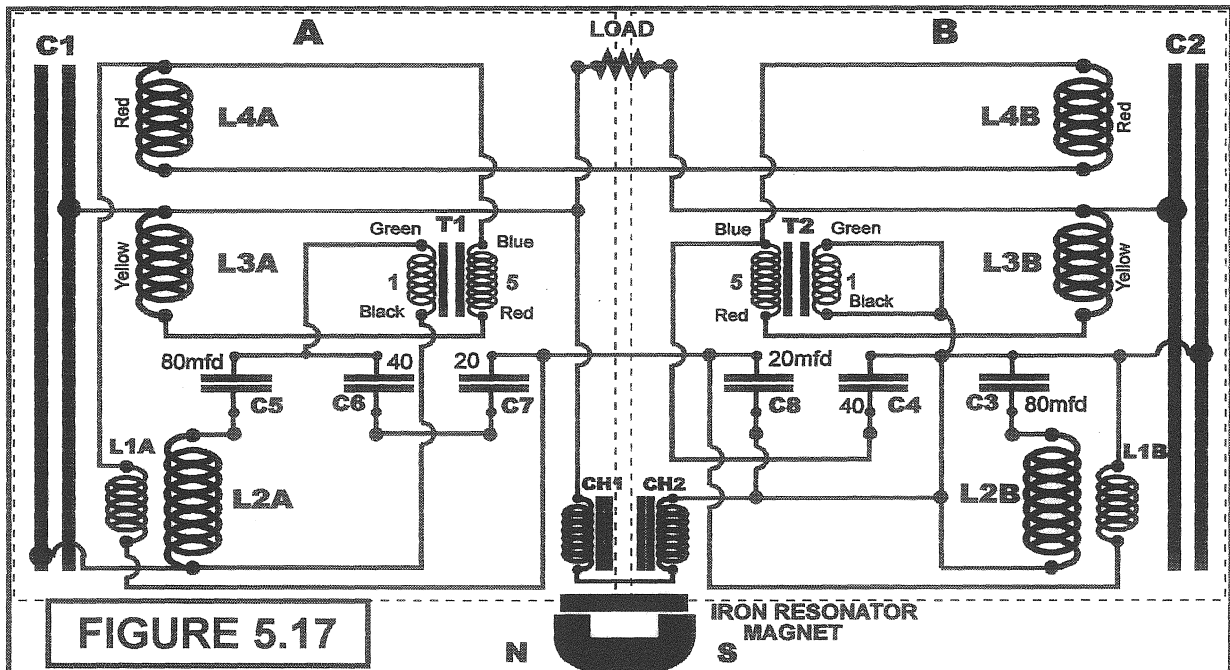

FIGURE 5.17

**Redrawn Original O'Brian Circuit of the Mark IIIC Design
from Figure 5.16**

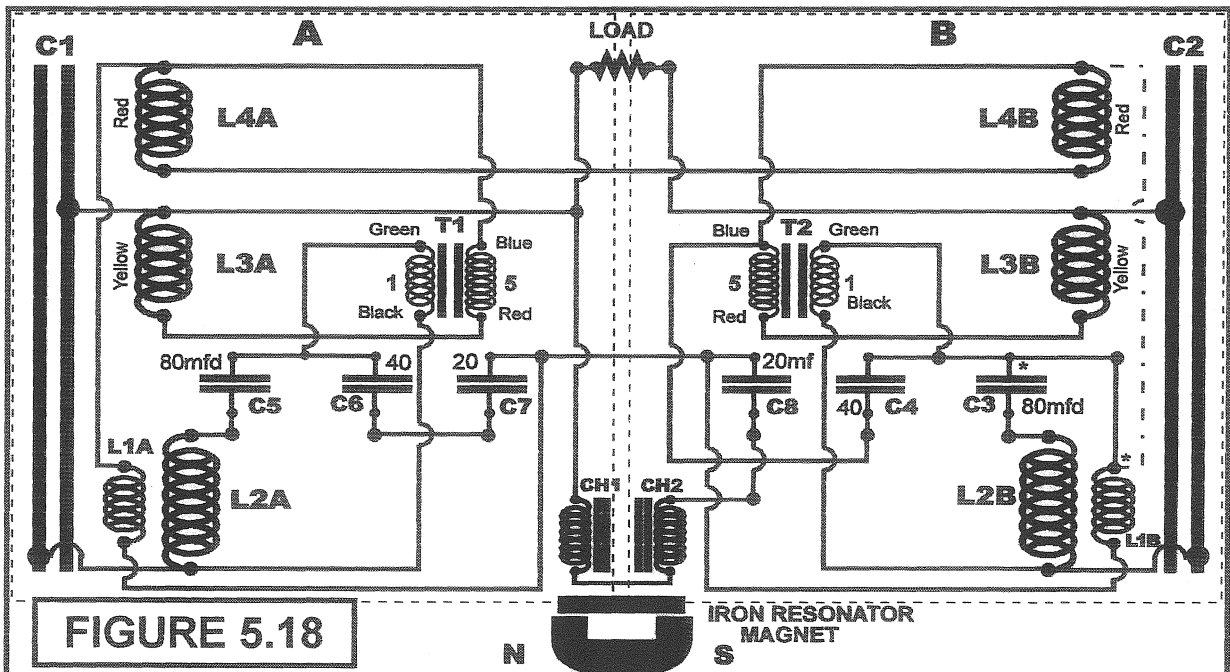

FIGURE 5.18

Author's modified Circuit Design of Figure 5.17

In Figure 5.18 on the previous page, I have modified O'Brian's circuit to eliminate the short circuit of T2 primary by duplicating the symmetry of Bank "A". By doing this, I have provided a more conventional inductive/capacitive arrangement of component connections. As another alternative, I suggest connecting the upper ends of coils L4B and L1B, and removing the connection between C3 and L1B. This will further improve the symmetry of the design. Although these modifications may not be the perfect solution to the circuit design, they certainly wouldn't be any worse than shorting out transformers. It is assumed all components, other than C7 and C8, are the same as in the Mark IIIB design except C5/C6 & C4/C3 are now separate units.

The Hand Wound Capacitor C1/C2

It is now time to consider the construction of the hand wound capacitors used in all of the Mark III designs. Constructional details have been adequately covered by both Ed Skilling in Appendix B and Mark Hendershot in Appendix C, but in the interests of clarity, I feel it would not be superfluous to provide some improved graphic illustrations to assist in both the construction of the capacitors (C1/C2) and the basket weave coils.

FIGURE 5.19

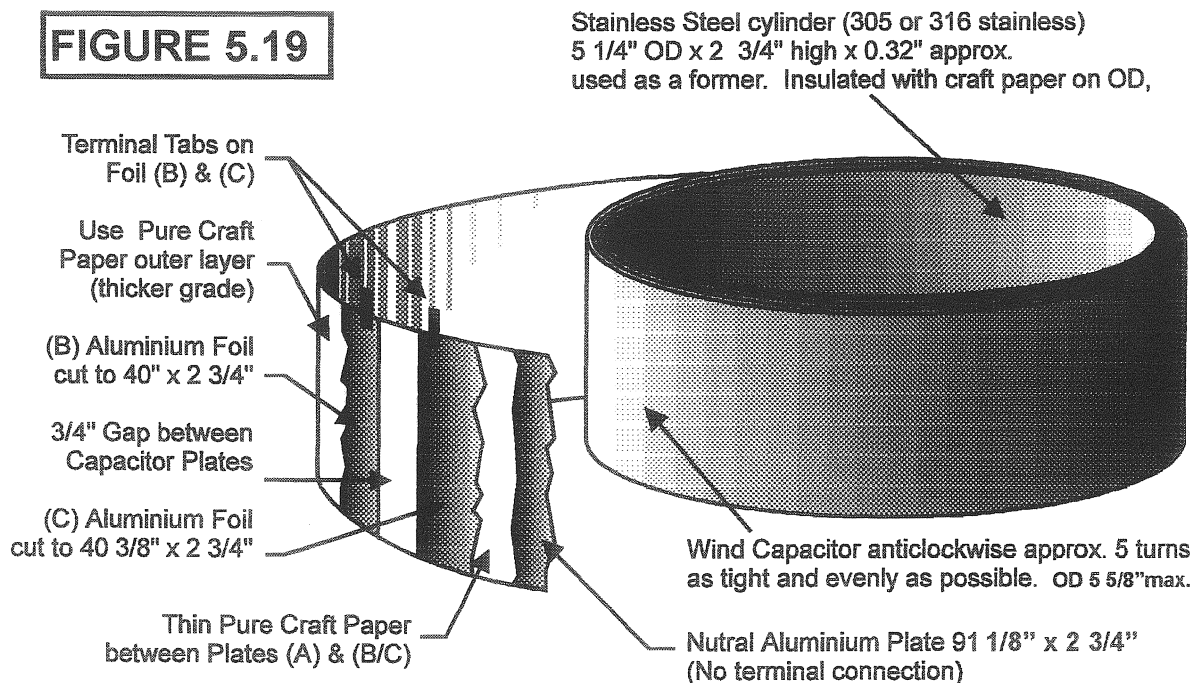

The above drawing shows the construction details for the Hand wound Capacitor C1 & C2 Mark III models

In Figure 5.19 I have used the data provided by Ed Skilling, because I consider this to be the most reliable. I have come across some other instructions that indicate the spit plates (B) & (C) are on the inside circumference, and that the stainless steel former is only 5" diameter. The outer layer of craft paper should be a little thicker than the one between the two sets of plates to provide better separation of the windings. Make the paper 3" wide, and a little longer than plate (A), to prevent shorts along the edge of the foil layers. Use some short pieces of double sided transparent tape to secure the foil to the paper insulation, instead of ordinary clear tape, because the tape may overlap the paper edges, and provide an electrostatic path between the foil laminations. Alternatively, to make a real professional job, use a light coating of tacky craft spay glue on the foil surface and allow to dry tacky before applying the paper to the foil strips. This glue, when dry, is a good insulator, and will not interfere with electrical properties of the capacitor. Any suitable aluminium foil will do, so it is not necessary to pull apart a capacitor. It is the balance that is important, not the 0.0078 mfd value. It can be anything up to 1.3 mfd as long as both C1 and C2 are identical value within about 1 or 2%.

FIGURE 5.20

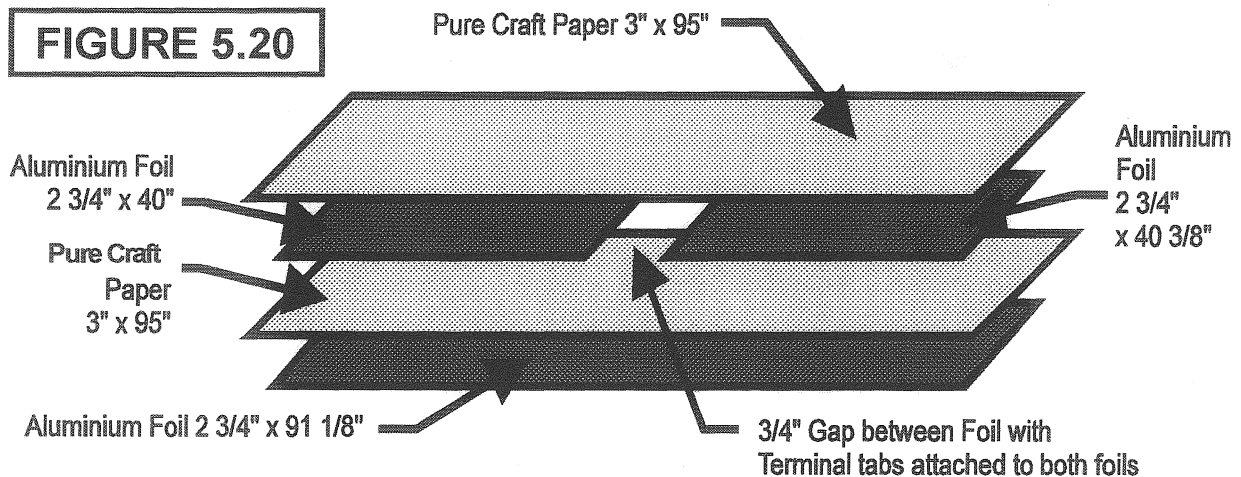

In Ed Skilling's article, he states Hendershot used a metal can cylinder for the former, in his early experiments, which proved unsatisfactory. As the metal can has ferro-magnet properties, stainless steel grade 305 (which also attracts a permanent magnet), may be suitable. 316 grade stainless, however, does not have ferro-magnetic properties and will not attract a magnet provided it has not been welded. I have had some previous dealings with energy accumulators similar to the hand wound capacitor assembly that would not function if the material was para-magnetic (See my book "The Joe Phenomenon"). In respect to the Hendershot Mark III device, the ferrous quality may be essential for the device to work, if this is the case, insure the stainless material does attract a magnet before using it. On the other hand, Burrige claims Hendershot used non-magnetic S/Steel.

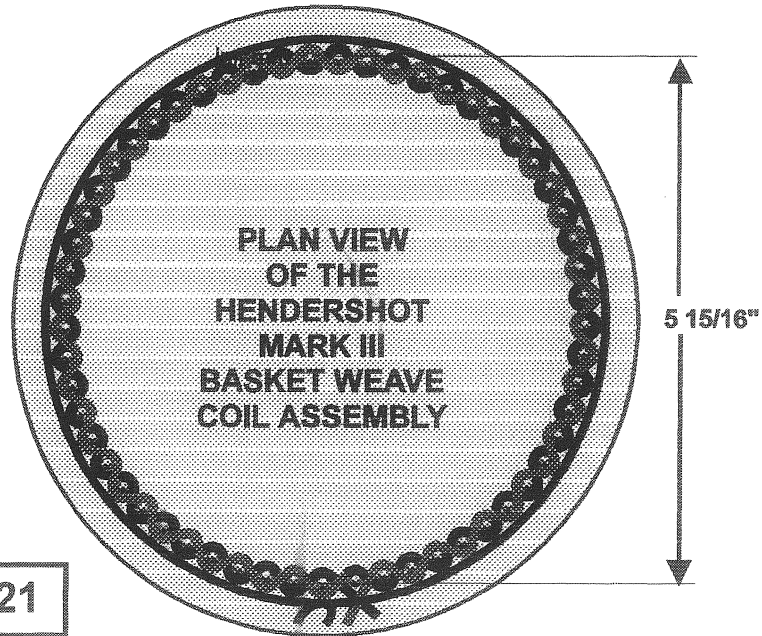
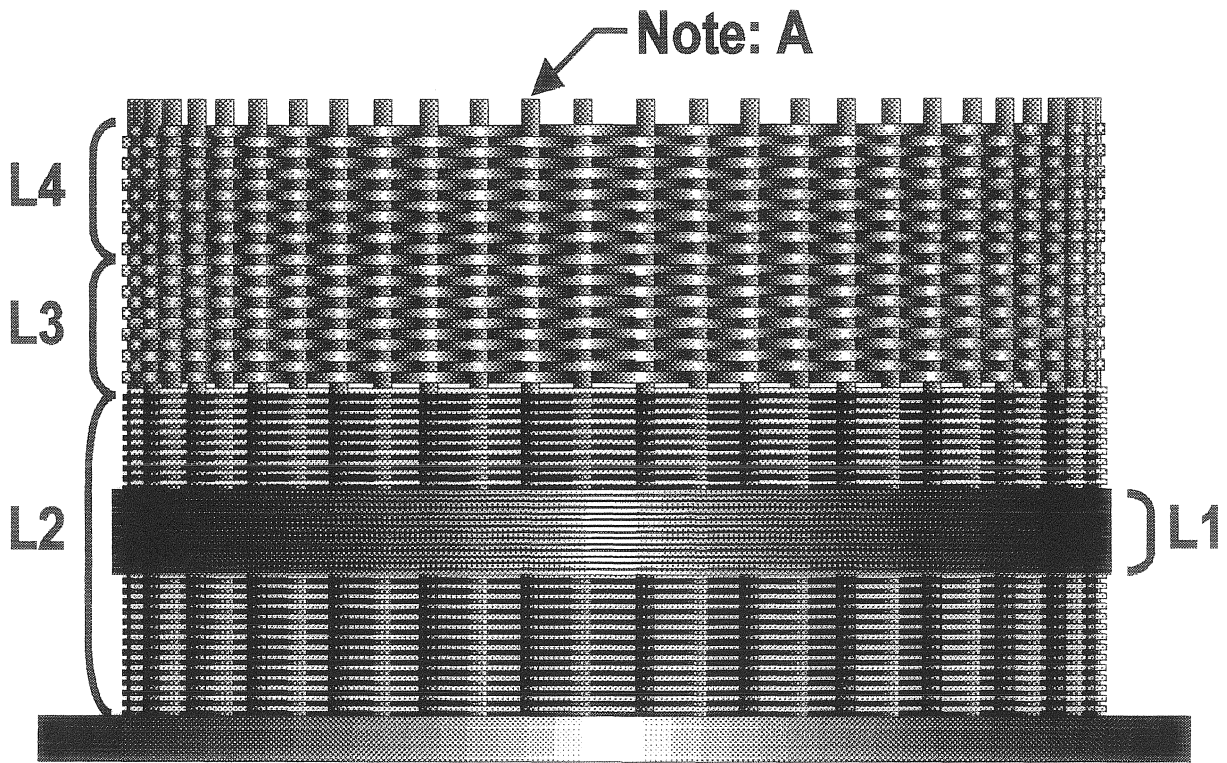

FIGURE 5.21

The Hendershot Mark III Solid State Power Generator Basket Weave Coil Assembly

The Basket Weave Coil Assembly

In Figure 5.21 is shown the Basket weave coil assembly. According to Ed Skilling's description,

- *L1* is a standard close wound coil which is mounted around the outside circumference of *L2* and positioned centrally on the *L2* winding. The *L1* coil consists of 14 turns of enamelled Formvar copper wire AWG 28, with a diameter of 0.0136". It is wound anti-clockwise looking from the plan view.
- *L2* is also enamelled Formvar copper wire, but consists of 64 turns of AWG 24, with a diameter of 0.0213. It is close wound in a basket weave configuration around the array of wooden posts shown in the drawing. This coil is also wound anticlockwise.
- *L3 and 4* consist of 25 feet each of Belden thermoplastic single copper core wire AWG 20, with a diameter of 0.0334" core and an OD of approx. 0.05". They are close wound coils above *L2* with the same basket weave configuration and the same anticlockwise direction of winding. The 25 feet will allow for 12 turns of wire for each coil. *L3* is colour coded "Yellow". *L4* is coded "Red".
- *Note A* in Figure 5.21 relates to the design of the basket weave former for the coil assemblies. It has a mean diameter of 5 15/16" for the arrangement of the mounting posts, which consist of 57 wooden dowels, each 1/8" diameter set around the circumference of the circle, equally spaced at 6.3158 degree centres. The pins protrude 3" above the plywood base plate in order that the end of the pins can extend slightly above the completed windings.

In Appendix C, Mark Hendershot explains some of the finer points in constructing the basket weave assembly. He also states to use plastic for the base. Using plastic for the base in place of plywood, *may or may not* cause an electrostatic disturbance to the function of the hand wound capacitors *C1* and *C2* situated at the centre of each basket weave coil assembly. Don't seal the capacitors in place with the wax until they have been checked for matching capacitance and they have been accurately positioned at the centre of the coil assemblies.

It is a good idea to silver solder the seam of the stainless steel former for the hand wound capacitors as this will not disturb the metal composition of the stainless, (Electric welding will!).

There has been some information circulated that Hendershot may have used counter wound coils for each of the windings. Skilling was specific in his findings that all of the coils were wound in the same direction. Coils wound in a counter-rotational manner are normally regarded as non-inductive coils, whilst those wound in a compatible rotational manner are generally considered inductive. It would seem therefore that Hendershot intended these coils to be inductive.

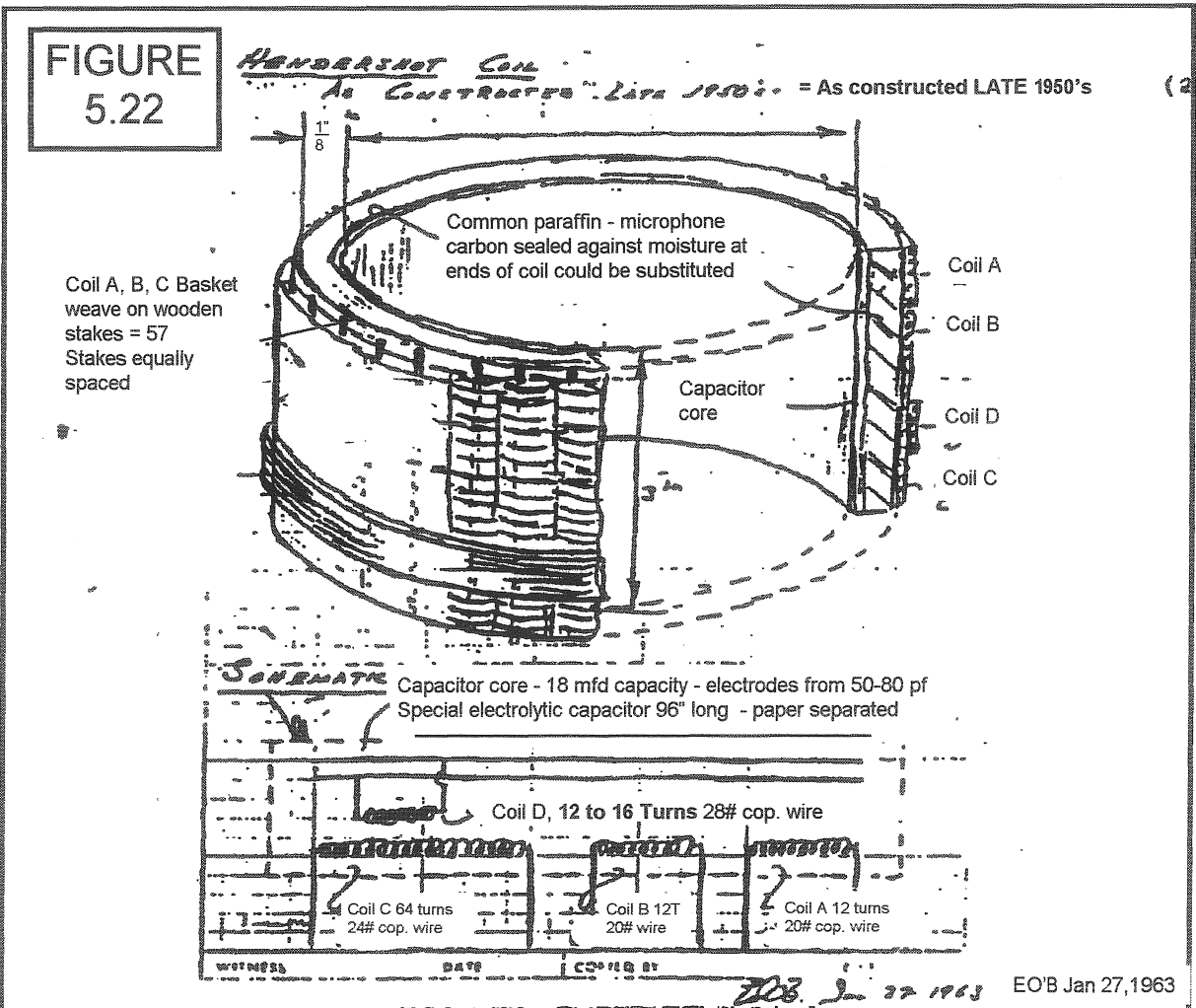

The above drawing at Figure 5.22 was drawn by Edward O'Brian from the device at Arthur Aho's home. It confirms the data supplied by Skilling and dates the device as being invented in late 1950's (Not 1930's)

There are two very interesting variations mentioned by O'Brian in Figure 5.22. The first point, is his note that states C1 (Coil D) may have 12 to 16 turns of AWG 28. The second, is his note inside the cylinder that states, "Common paraffin - microphone carbon sealed against moisture at ends of coil could be substituted." It may be that Hendershot did not use just paraffin between the capacitor energy accumulator and the outer coils, but instead, used a carbon compound which was sealed at either end by paraffin wax. If this information was provided by Aho, then this may have been one of Hendershot's little secrets. The use of carbon rods as a core for radio coils, prior to carbon ferrite rods, was fairly common in early radio receivers. It is also the best material for the anode in dry cell batteries and in the transmission of high energy pulses in the carbon arc process. However, there is a possibility that this idea was thought up by O'Brian and may therefore have no bearing on the device created by Hendershot. It has also been suggested by a friend of mine that a radioactive material between the capacitor accumulator and the coils could also have a positive effect. If one is unable to achieve any results using the Skilling directions, these points may be worth keeping in mind. Some fire detectors use a small amount of radium in the detector which could be used for this purpose and could then be added to a carbon powder mix.

The Electromagnetic Oscillator Assembly

In Skilling's description of this part of the device, he states Hendershot used a permanent magnet from a radar magnetron. This magnet has three poles (See Figure 5.5); two south poles (One on either leg of the horseshoe), and a single north pole at the centre leg. In some of the earlier designs (See Figure 5.1 and 5.2), Hendershot used a standard horseshoe (two pole) type. It may be assumed that he changed over to the magnetron type for better distribution of the magnetic flux throughout the length of the clapper plate, giving better perpendicular controllability over the motion of the clapper and thereby better reliability.

Skilling states that the electromagnetic bobbin wound solenoids came from an old telephone bell ringing circuit, and he further stated that conventional door bell coils should also do the trick. These devices use a ferromagnetic strip suspended (from a spring) a short distance from the cores of the coils. When power is supplied to the coils, the cores become magnetised and overcome the resistance of the spring to draw the metal strip towards the solenoids.

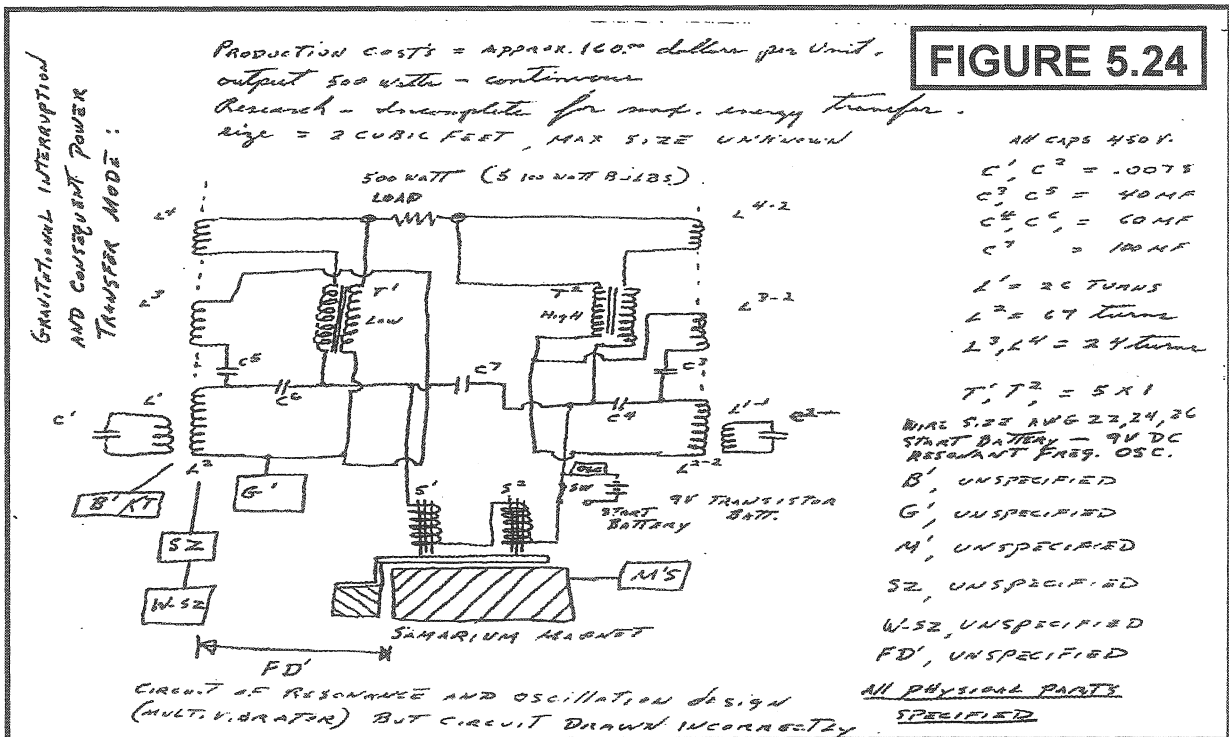

The above circuit was also released by R. H. Crabb and shows a similar arrangement to Figure 5.23, but in this arrangement the power is applied across CH1 & CH2.

Fig. 5.23 & 5.24 were designed by J. G. Gallimore and believed to have worked?

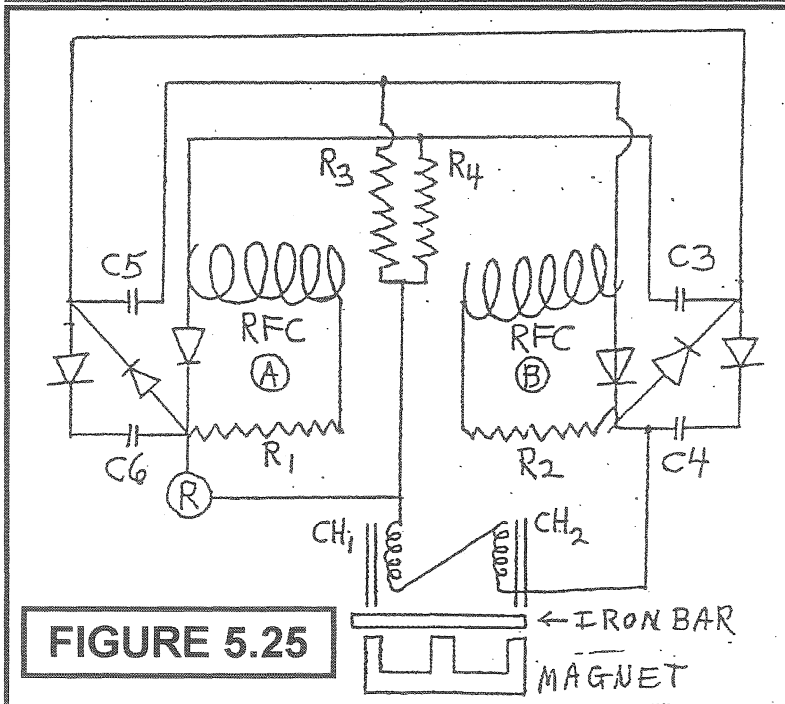

The accompanying drawing at Figure 5.25 is an interesting alternative to Hendershot's conventional circuits.

I believe the circuit may have originated in an article by John Bigelow in "Earth Energy"

Just who designed this circuit or if it was every constructed I am not certain

SUMMARY

It has been my intention in this Chapter to include all the relevant written information that has been presented since 1958 on the subject of the Mark III devices. Unfortunately all of those directly involved have long since passed away, and therefore I am unable to gain any first hand information that may help to eliminate the various inconsistencies and variables revealed. But from this written evidence, a more coherent and comprehensive account of the details and history of the Hendershot devices have brought us closer to the truth. And from that truth, it may now be possible by a process of elimination to finally achieve those results that only Hendershot himself was able to achieve.

I have particularly avoided including any of the various unconfirmed hypothesis put forward to explain the Hendershot phenomenon other than that offered by Lester Hendershot, (See Appendix C). I consider such inclusion would not have contributed anything practical to the evaluation. However, I do feel that this chapter would be incomplete without some rational hypothesis that may help to provide some understanding of how the device functions to produce the output power that Figure 5.4 visually demonstrates was achieved by Lester Hendershot.

The entire process appears to start with the vibrations of the resonator circuit. The oscillator (or clapper) device probably serves two basic functions. The first is to act as a useable frequency generator, and the second, is to provide a low frequency heterodyning effect on the incoming extremely ultra-high frequency of the amplified energy signal. As this incoming signal is believed to be in the gigahertz range, the mechanical resonator can only respond to a quanta of impulses that are rectified and built up across the capacitor C1/C2 and directionally choked by the bridging coils L1A/B in the Mark IIIB configuration (Slightly different in the Mark IIIC model). For each cyclic response of the resonator, the electromagnetic field of the circuit is momentary interrupted, causing a reverse current flow and discharging the potential build up across the capacitor accumulators. A useable amplified power signal is therefore produced across the output terminals as a result of a suitably designed circuit that can amplify and reinforce one or more of the resulting harmonics.

As indicated by Aho, the clapper has a peak oscillation of around 60 hertz (Although a mechanical resonator can vibrate at up to 300 hertz with reliability), whilst the overall circuit is self resonating at around 500 kilohertz according to Skilling. It is therefore primarily this harmonic that releases the powered impulse to generate the necessary output wattage. It is maintained by a constant build up and collapse of the incoming signal collected by the accumulator circuitry and caused to resonate back and forth across the two halves of the Hendershot solid state generator by the action of the induced clapper oscillations.

Remember this hypothesis is based on proven fact, not hypothetical fiction! Whether it is derived from the electromagnetic field of the earth or the cyclonic ether wind that creates it, is immaterial. The important thing is, that it is real. It can be tapped for the benefit of human endeavour, and it is inexhaustible.



THE HENDERSHOT ENIGMA

The Hendershot's Free energy generator demonstrated at Selfridge Airfield in February of 1928, and the demonstration of his "fuelless" electric motor during the same period, caused some considerable confusion when the story broke on the 25th February 1928. In the early stages, it was assumed that Hendershot had invented only an electric motor, and neither Hendershot nor Lanphier did anything conclusive to clarify the situation. While Hendershot was talking about a 45HP motor, Lanphier was talking about a generator that burned out conventional motors and lit light globes. Even to this day, there has been no clear story or what actually transpired at Selfridge Airfield during the month of February 1928.

In an article appearing in Round Robin, Vol. XI, No.6, March/April 1956, and written by Gaston Burrige, (See Appendix B), Colonel Lanphier (now retired) was interviewed by Burrige. In this interview Lanphier was reported as saying that no device was ever constructed at Selfridge Airfield whilst he was in command, and the device demonstrated at the airfield by Hendershot was proved to be a fake. He didn't say if this was the motor or generator or both.

Evidently, Lanphier, like Hendershot, had been silenced. His statement to Burrige was a complete and utter contradiction of his statements made to the New York Times on 27th February 1928. It appears that even twenty-eight years after the event, Lanphier was still too scared to re-affirm his earlier statements and explain the real truth of the whole saga. When Burrige confronted Hendershot with Lanphier's statement, Hendershot confirmed that the device was built at the airfield by army technicians and that it did work as reported in the papers at the time. However, Hendershot refused to answer any other pertinent questions.

Relying therefore on the Lanphier statement to the NYT on 27th Feb 28, it can be assumed that the device Lanphier helped to build was indeed a generator (and maybe doubled as a motor). The independent tests carried out at the airfield on the device by army engineers and constructed by them, proved the device to be genuine. It is not clear, just who constructed the larger motor and at what location, and if this was the same device described by Lanphier, but it is evident that such a motor had been constructed, completed and tested between the time of the Berris Airfield demonstration of the model aircraft motor and the tests conducted at Selfridge Airfield. Hendershot's own statements to the New York American on 26th Feb 28, confirms the data on the larger motor's performance.

From the statements of Major Lanphier (NYT 27 Feb 1928), the coil diameter is stated (for the first model) to be around 3 inches. The second model built at the Base, is stated to be 6 inch inside diam. and 7 inches outside diam. His description contradicts the patent specifications at Appendix D, as he states "The first model consisted of a ring magnet less than three inches in diameter. Around the magnet were coils rigged as only Hendershot knows how to rig them and another set of coils pass through the centre of the ring. He further states "The second model is built around a ring magnet" also. If Lanphier's description is correct, then it is clear that the device described in the patent application is not the same, although there are some similarities. Unless he means the ring magnet was located inside the coil and did not form the core for the windings, as in Figure 4.1.

This may be the solution to the riddle. If the motor and generator were one in the same device, then Lanphier's statement would be a reasonable description of the complete motor device described in Chapter 2. In Hendershot's statement to the New York American on 26 Feb 1928, he state "The engine actually makes it own electricity." And Peat is reported in the NYT 28 Feb 1928, The secret is "the method of winding a magnet in the motor...". If the armature shown in Figure 2.1, were surrounded with Hendershot's honeycomb winding described in the patent draft and used as a stator, then Lanphier's description, Hendershot,s description and Peat's description would all correspond.

Mark Hendershot's release of the patent application and accompanying sketch only adds more confusion to the story. I think it is fairly obvious, that the device described in the patent application and the description of the Hendershot's devices by the major at the time, have only basic similarity.

It is assumed that Colonel Lindbergh had witnessed a device made by Hendershot some time during January 1928, as the date on the Patent attorney's letter to Hendershot was 4th February 1928. It is stated by Mark Hendershot, that the attorney engaged to prepare the patent was Lindbergh's patent attorney in Washington. It is most unlikely, to say the least, that Lindbergh would be so involved, unless he had some first hand knowledge of a working device. The Selfridge Field involvement, was therefore not just to demonstrate the device, but arranged between Lindbergh and Lanphier to put the device through vigorous tests by the Base engineers, to determined its viability and if any fraud was being perpetrated by Hendershot. It is probably for this reason that the army engineers built the larger device with only verbal instructions given by Hendershot.

The release of the Patent Attorney's covering letter, now only adds to the mystery. The report by Major Lanphier in the New York papers indicated that patents first had to be obtained before the commercial development of the device could proceed. It is clear from this statement, that Hendershot had not made any attempt to patent his inventions demonstrated, prior to Lanphier's and Lindbergh's involvement. The whole purpose of the exercise initiated by Peat, was to interest the army (and corporate investors) in an electrical motor that could power aircraft. Why then did the Patent Attorney's letter contain no reference to the "Fuelless" Motor? Why did Lindbergh only arrange for a patent draft for a solid state device generator that had no dynamic components that could be considered to be described as a motor? Where was the patent details of the aircraft motor that was used in the model aircraft?

In the years that followed this saga, no mention was ever again made of a "Fuelless" electric motor, until Mark Hendershot's release in 1995/96. The individuals who worked with Hendershot on his inventions since the 1930's, refer only to a solid state device as publicly released by Skilling in 1962, and even this device has only basic similarities to the Mark I & II devices already explained. It will therefore probably remain a mystery why only a patent application for a solid state device had been initiated, when there is clear evidence to indicate that this device was functionally different to that described in the press.

Somewhere out there, locked away in the secret archives of the US military, or in the documents of the Mexican government (with whom Hendershot worked in 1956/57), or in the files of Lloyd Cannon (who prepared a dossier on Hendershot's inventions in 1960 and distributed this information to pertinent US government departments), or maybe still within Hendershot's own remaining personal papers, there are plans for a successfully proven "Fuelless" Electric Motor, that could solve all our surface transport needs for the rest of human existence. The real master criminals, are not the scientist, inventors and users of technology, but the VESTED INTERESTS, whether government, corporate or individual, who seek to suppress and prevent the use of these environmentally friendly devices in the interests of their own greed and ignorance. If his inventions had been commercialized, our use of Power stations and petrol driven vehicles may have become an almost forgotten memory and the whole course of human history would have taken a markedly different turn. We are therefore left with a riddle, from which the Hendershot legacy has proven, that power is possible for all - without monopolisation - without use of fossil fuels and without its resultant planetary degradation - just sitting there - free for the taking - IF ONLY WE KNEW HOW!

HENDERSHOT NEWSPAPER TRANSCRIPTS

The New York Times

Sat. Feb 25, 1928, 1-283, V, 77, N, 25, 599

**Col. Lindbergh Helps to Test a New Motor,
Said to Use Electro-Magnetism, *No Fuel***

Special to the New York Times

DETROIT, Mich., Feb 24 - Colonel Charles A. Lindbergh and Major Thomas Lanphier tested at Selfridge Field today a new type of motor which, it is predicted, will revolutionize power for airplanes and possibly automobiles and electrical power machines.

The motor is said to employ electro-magnetism in connection with the rotary motion of the earth. It uses no fuel. Colonel Lindbergh and Major Lanphier joined in the test with Lester J. Hendershot, the inventor, and D. Barr Peat, his business partner, both from Pittsburgh.

The motor has been guarded with the greatest care since it was brought to Selfridge Field by Hendershot and Peat. Late today it was taken to an experimental hangar, where the transatlantic flier aided in the tryout. This was declared to have exceeded the hopes of the inventor.

So far as experiments have been made, the power has only been applied to airplanes. Later developments are planned to extend the scope of operations to other fields of locomotion.

No other facts were obtainable tonight other than the machine runs on electro-magnetism. It is in no sense connected with a perpetual motion idea, although recent tests have shown that it will run indefinitely.

On the test blocks today, it was learned the motor turned up 1,800 revolutions a minute. It would run at this rate for between 2,000 and 3,000 hours before it would be necessary to recharge the magnet centre, it is said.

Colonel Lindbergh and his mother are expected to leave Selfridge Field early tomorrow morning on the first hop of a flight to Boston, where they will attend the annual meeting of the National Education Association.

The plane in which Mrs. Lindbergh will be a passenger, a three-motored army transport, arrived this afternoon from Dayton. It is piloted by Lieutenant Harry Johnson and Albert P. Hegenberger, the latter a transpacific flier.

DETROIT, Mich. Feb. 24 - The Detroit Free Press will say in a copyrighted article, tomorrow that the Guggenheim interests have arranged for an immediate conference with Lindbergh, Lanphier and the owners of the new motor.

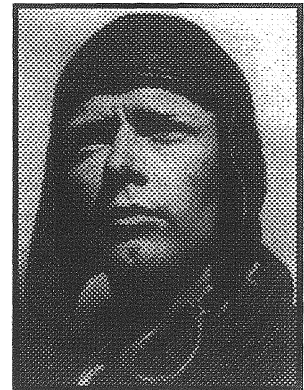

The New York Times

Sun, Feb. 26, 1928, 1-4;2-4thru7,V.77,N.25.600

FUELLESS MOTOR IMPRESSES EXPERTS

*W.B. Stout. Says, "Invention Works Uncannily - Washington
Think It Important.*

Built on Radio Principle

Armature Winding New - Inventor Inspired by Young Son Lindbergh Flies Here

DETROIT Mitch Feb 25. W.B. Stout head of the Stout Air Lines and designer of the all-metal trimotored Ford monoplane, declared here today that he had seen what he characterized as an "impressive" demonstration of the Hendershot fuelless motor two weeks ago in Pittsburgh.

Lester J. Hendershot, the inventor, and his associate D. Barr Peat, who is manager of the Bettis Field at McKeesport Pa., demonstrated the motor secretly yesterday in a hangar at Selfridge Field. This block test was witnessed by Major Thomas G. Lanphier, Colonel Charles A. Lindbergh and others.

It was explained today that the model used in the demonstration was a much smaller machine than an actual working motor capable of developing power enough to lift and propel an airplane. Its designers claim for it that it runs on an electromagnetic principle, by which it draws its force directly from the earth's field, and through the properties within the motor itself transforms these electric currents into power that can be delivered efficiently at a propeller shaft.

Calls Demonstration Uncanny - "The demonstration was very impressive," Mr. Stout said. "It was actually uncanny. I would like very much to see how a larger model designed to develop power enough to lift an airplane would operate.

Mr. Stout said the model he saw was about the size of the tiny electric motors used in vacuum cleaners. "I was told that the revolutionary feature was a hitherto unknown manner of winding the armature." Mr. Stout continued; "Hendershot said he had succeeded in winding it in such a way that it draws energy directly from electrical currents which exist constantly in the air or in the ground. Such sources of cheap and inexhaustible power of course never have been reached before. The small model appeared to operate exactly as Hendershot explained that it did."

Neither Colonel Lindbergh nor Major Lanphier would express themselves at length on the test they witnessed yesterday. Major Lanphier admitted, however, that they were experimenting with it and referred all questions to Hendershot.

"He is the only one who knows all about it," the Major said. "Lindbergh has nothing to do with it although he saw it."

William B Mayo, chief engineer for the Ford Motor Company was in conference with Major Lanphier, Hendershot and Peat at Major Lanphier's quarters today.

Corporation Being Formed

DETROIT, Feb 25 - A corporation has been formed to develop the "free energy" motor invented by Lester J. Hendershot, Pittsburgh electrical engineer, and incorporation papers are to be filed by Henry Breckinridge, attorney, in New York it was said here today by Major Thomas G. Lanphier, Selfridge Field flight commander.

Major Lanphier who left this afternoon by air for Mitchell Field, Long Island, said before his departure that he was interested in the corporation, but he declined to name other persons interested.

Earlier in the day Major Lanphier said Colonel Charles A. Lindbergh was not connected with the enterprise, yet Mr. Breckinridge is Colonel Lindbergh's attorney.

Whether the motor will prove practical and revolutionize the automotive world will depend upon future tests, it was said today, by aeronautical experts who have viewed tests of the model.

Major Lanphier, who with Colonel Lindbergh witnessed a private demonstration yesterday said the motor had great possibilities, but "it might not amount to anything. It is too early to tell anything about it", he said.

William B. Mayo, chief engineer of the Ford Motor Company, was in conference with Major Lanphier, Hendershot and Peat in Major Lanphier's office prior to the Major's departure today. He declined to make any statement upon leaving. Major Lanphier and Colonel Lindbergh held a previous conference with Ford officials at the Ford plant on Thursday. Whether these conferences had any connection with the development of the Hendershot motor was not learned.

INVENTION RESULT OF DREAM

Hendershot Made First Fuelless Motor for His Son's Toy Plane

WEST ELIZABETH Pa., Feb. 25. - The invention of the fuelless motor, tested at Detroit was the result of a dream by its inventor Lester Jennings Hendershot who lives on "the street back of the railroad" in this town of about 3,000 inhabitants, fifteen miles from Pittsburgh.

Although Hendershot was on his way from Selfridge Field today and is not expected home until tomorrow, his wife told of his conception of the machine and of how the miniature model was constructed from the parts of a worn out radio which had been given to the inventor by his uncle.

Several years ago the vision of a machine which would operate from "earth currents" came to Hendershot in a dream, according to his wife, but it was not until last November that he actually started work on it.

His 4 year old boy had a small airplane at that time and was considerably chagrined because it would not operate. The father was disturbed too, so he told his son he would build an airplane which would work. The result of that was the fuelless machine.

First Model Worked Toy Plane - When the miniature motor model had been constructed, Hendershot built a small airplane and placed the machine in it. A switch was turned and immediately the propeller began to move. The machine was not connected to any electrical current, but was running of its own accord from "earth currents."

For several weeks the little motor and airplane rested upon a small table in the living room of the Hendershot home, which faces an unpaved street near the railroad tracks. One day D. Barr Peat of Bettisfield, the air mail port near McKeesport Pa., visited the Hendershot home to see the model. He immediately became enthusiastic and a few weeks later he and Hendershot were at Selfridge Field where permission had been granted to build a model large enough to operate an airplane.

Hendershot who is only 29 years old, was born in Hyndman Pa., His schooling has not been extensive although he spent a few months several years ago at Cornell University. where he took a few courses in mechanics. He has not been consistently employed at any particular task and has been known as a "free lance" worker. He has been a fireman, an engineer on the railroad, has worked in the mills near Pittsburgh, has inspected concrete and done electrical work. During the war he was a bugler with a machine gun company, but did not get overseas.

Still Wants to See "How They Work"

According to his mother, he has always been interested in mechanics and when a child he would insist upon taking his play things apart.

And that desire has not escaped him as a man for even now he takes his own son's playthings apart to see how they work..

It required only a few weeks for him to construct the miniature model of his fuelless motor, although he worked day and night during that time. He had a crude work bench in the cellar of his home, which was placed near the furnace, where it was warm. Early in the morning he would be there, tinkering about and late at night he still could be found there.

Hendershot's idea was that the earth currents which make the aurora borealis in the skies could be harnessed by man and made to produce power that would operate an engine.

The youthful inventor has no other inventions to his credit.

Works on Principle of Compass

PITTSBURGH Pa. Feb 25 Lester Hendershot first came to Bettis airplane field in McKeesport between two and three years ago, and soon afterward brought one of his motor models to the officers of the field for inspection.

The fuelless motor works somewhat on the principle of a compass and the original model would always operate when pointing north or south as does the compass but would not move when pointed east or west.

Young Hendershot worked nearly two years to overcome this defect and finally he brought a motor to the Bettis Field that appeared to be working perfectly. This motor was installed in a small model airplane and the plane flew, but owing to the failure to rig it properly, it crashed to the ground during one of the experiments.

Constantly improving the motor Hendershot finally interested D. Barr Peat, manager of the Bettis Field, in his invention.

After a short time several capitalists were interested, and a few weeks ago the motor was taken to Detroit by Hendershot and Peat for an exhibition.

While no person at the field was in position to say authoritatively, it was stated that the capitalists who have become interested in the Hendershot motor have about completed their arrangements for the purchase of the invention and for controlling its production.

The fuelless motor, it is said, appears to have tremendous power and easily made, between 1,500 and 2,000 revolutions per minute on several occasions while being tested at the field. Pilots and mechanics believe it to be the greatest invention of the age, and all appear sure it will be a practical success as an airship motor.

It was stated at the field that the inspection of the motor by Colonel Lindbergh was made in the interests of the capitalists who are arranging to purchase the invention.

WASHINGTON INTERESTED *Army Officers Had Heard of a Revolutionary Invention*

WASHINGTON Feb 25 - Keen interest was shown in Government aviation circles today over reports from Detroit that Colonel Lindbergh and Major Lanphier had witnessed a test of an alleged fuelless motor.

Among officers who know Major Lanphier, there was a disposition to believe that the invention was important. Some recalled that recently he was reported to have intimated that he was interested in a matter that would have revolutionary results on aviation. Navy officers said it had long been recognized that some such engine might be developed.

Lieut Commander J.M. Shoemaker, head of the airplane engine department of the Navy Bureau of Aeronautics, who is a member of the subcommittee, said "the invention would be remarkable if true".

Members of the subcommittee on power plants for airplanes of the National Advisory Committee of Aeronautics were in session today, but their only information was contained in the press accounts from Detroit.

Dr. S.W. Stratton, President of the Massachusetts Institute of Technology, who is Chairman of the subcommittee, said he could form little idea of what the engine might be but thought that as described, it would appear to be "not practical". It might be possible, he admitted, to build a magnetic engine that would work, but it probably would weight 1,000 times as much as an airplane.

Major Lanphier has long been a close friend of Colonel Lindbergh. Graduated from the Military Academy in 1914, he has been in the Army Air Corps since 1920. He has made noteworthy flights from Selfridge Field to Cuba and to Texas.

GUGGENHEIM CALLS IT INFANT

Says No Predictions Can Be Made Yet for New Motor

SANTA BARBARA Cal. Feb 25 - Harry F. Guggenheim, President of the Guggenheim Foundation for the Advancement of Aeronautics, believes the new electro-magnetic motor tested yesterday at Selfridge Field is too infantile in its development to warrant predictions as to its effect on locomotion.

Mr Guggenheim who is spending six weeks in Santa Barbara, said today that Major Thomas G. Lanphier brought the motor to his attention several weeks ago.

"I suggest that patent rights be secured before anything further was done." Said Mr. Guggenheim, "The Guggenheim Fund will be glad to carry out investigations and experiments. But it is too early to announce the effect the new motor will have on locomotion."

Mr. Guggenheim expressed surprise that any report of the experiments had been made public, saying premature predictions that the new motor would revolutionize locomotion might retard the advancement of aeronautics.

WANTS MORE FACTS ON MOTOR

Engineers Here Are Loath to Comment on Reported Invention

While aviation engineers and pilots here were much interested yesterday in the reports from Detroit of a fuelless motor they all wanted more information on the mysterious power plant before expressing an opinion about it.

William H. Meadowcroft, a pioneer experimenter in electricity since 1881, who has been associated with the Thomas A. Edison laboratories in East Orange, said last night that he had not heard of any experiments being carried out with an electric motor using the earth's currents directly as a source of power exclusive of generating plant and batteries. "I would like to know more about it before commenting on it," he said.

Professor Alexander Klemin, physicist of the Guggenheim School of Aeronautics at New York University, to whom the funds refers, plans and inventions having to do with aviation, said last night of the Detroit test:

"I am interested of course, but on the meager descriptions in the press, I would not care to comment. The laws of physics are pretty rigid and there is no way of getting something for nothing. Of course, we know of the magnetic field around the earth, but it is only through some chemical or atomic means that we can derive energy." Neither he nor H. Allen Sullivan of the Guggenheim Fund were inclined to take the new motor seriously until they had received a more detailed description of it.

Dr. Michael L. Pupin, Professor of Electro-Mechanics at Columbia University, told the Associated Press that he could not consider the subject seriously.

"According to my knowledge of science I cannot understand how sufficient power can be generated in this manner to operate a heavy object. I do not understand it and fail to place any importance in it he declared."

Baltimore Professor Dubious

BALTIMORE Feb 25 - The theory that the new motor tested at Detroit derived its motive power from an earth current was received skeptically today by Dr. J.B. Whitehead, Dean of the John Hopkins School of Engineering. His reaction to newspaper accounts he said, was that they were "interesting if true".

LINDY IN N.Y. TO PERFECT MAGNET MOTOR**Engine 28 Inches Long and Weighs 130 Pounds,
Designer States**

NEW YORK Feb 26 - The New York American in a copyrighted article will say tomorrow that Colonel Charles A. Lindbergh or Major Thomas Lanphier has brought to New York the electro-magnetic motor of Lester Hendershot for purposes of perfection and production.

The motor will be taken to the office of the Guggenheim Fund for the promotion of aeronautics tomorrow, the paper will say.

"Despite protestations of Lindbergh, H.K. Knight and others that they were in New York on a pleasure jaunt and that they positively would have nothing to do with production of the invention, it was learned they had brought the motor here for that sole purpose," the paper will assert.

Hendershot, designer of the engine will arrive Tuesday to continue negotiations with Lanphier, Lindbergh and the Guggenheim representatives, the paper will say.

In commenting on the invention it will say Hendershot said, "The engine actually makes its own electricity. There is a magnet which acts as a starter. From that point on it generates its own power. The magnet will not wear out under 2000 hours, nearer 3000."

"And contrary to reports already circulated, the model is not the size of a vacuum cleaner motor. It is twenty-eight inches long. It weighs 130 pounds, it has developed 45 horsepower at 1800 revolutions a minute, the average speed of internal combustion motors."

The New York Times February 27, 1928

FUELLESS MOTOR IS A GENERATOR

*New Hendershot Device Has Enough Power to Kill a Man
Lanphier Says*

EXTENSIVE TESTS AHEAD

*Major Adds That Much Remains to Be Done
Before Invention Can Be Applied Practically*

The Hendershot "fuelless motor" is not a motor at all but a generator, according to Major Thomas Lanphier, commandant at Selfridge Field, which, were he with Lester Hendershot, the inventor and D Barr Peat have been quietly working on an experimental model. Major Lanphier started for New York from Selfridge Field in an army pursuit plane a few hours after Colonel Lindbergh took off. The army officer was forced down at Buffalo and completed his journey by train arriving here yesterday morning.

Major Lanphier said he first became interested in the Hendershot electrical machine several weeks ago through Peat; that in common with others he thought it was more of less "bunk" but after seeing it work he became interested.

"I saw the first model which Hendershot built hooked up to a small electric motor of the type used to operate a sewing machine. It not only ran that motor but it burned it out", Major Lanphier said.

Why this generator acts as it does, where the energy comes from that transforms it into power Major Lanphier was not prepared to say beyond quoting Hendershot. It is the inventor's theory that his machine draws its energy from the earth's magnetic field. While unwilling to describe it in detail until pending patents have been received, Major Lanphier told a little about it. The first model consisted of a ring magnet less than three inches in diameter. Around the magnet were coils rigged as only Hendershot knows how to rig them and another set of coils pass through the centre of the ring.

With this contrivance we burned out the sewing machine motor and we also kept a 100 watt lamp going with it for twenty-six hours, he said.

The larger model which has not yet been hooked up to a motor that can deliver power to a crankshaft, Major Lanphier himself helped to build.

"We put it together out of stuff we picked up at the field and with it we lighted two 110 watt lamps." Major Lanphier said. "I think that we have got enough electricity in this second model to kill a man."

The second model is built around a ring magnet, the outside of which is seven inches and the inside is six inches. The army officer in explaining the generator declared that he himself was no electrical wizard. His knowledge of physics ceased he said, with what he acquired in his classes at West Point. He is convinced however, with the results attained so far that the thing is well worth experimenting with.

It was suggested that perhaps the Hendershot engine was "stealing" power from some big radio broadcasting station.

"We thought of that" Lanphier said, "but we ran it for twenty-six hours when stations were going and when they were not and we got the same results.

The army officer paused in his meager description of the generator to declare that Colonel Lindbergh had no connection with the group interested in it.

"There are only Hendershot, Peat, myself and Henry Breckinridge," Major Lanphier said.

Professor Alexander Klemin of the Guggenheim School of Aeronautics, whose said last night that he would be glad to provide a place for the proper laboratory experiment on the Hendershot device, asserted that the weight of the motor would be no great bar to its use in a plane, because of the great weight saved in not having a fuel load.

Major Lanphier spent some time yesterday in conference with Mr Breckinridge and Colonel Lindbergh adhered to his declared program of "keeping out of sight."

"Slim wants to get out of the picture and rest and we are going to help him." Major Lanphier said, and then declared that Lindbergh's closest friends had persuaded him for the present, at least, not to align himself with any business organization in aviation or out of it.

"Lindbergh means too much to aviation", Major Lanphier said, "as he is. Once he joins some company he becomes a competitor. He belongs to all aviation now."

Beyond his trip to Albany as the guest of the Legislature on Wednesday, his friends said Lindbergh had no plans beyond rest and play.

The New York Times February 28th 1928

HENDERSHOT COMING HERE

PITTSBURGH Feb 28 1928. Lester J. Hendershot at West Elizabeth, inventor of the "fuelless motor" today denied all knowledge of a corporation in process of formation by Detroit friends to exploit his creation, but made known that he would go to New York Tuesday to confer with Colonel Charles A. Lindbergh and others prominent in the world of aviation. The model of the motor which was on display in Detroit last week has been sent to New York, Hendershot said.

LAYS A CLAIM TO IDEA

Seattle Youth Says He Discovered Principle of "Free Energy".

SEATTLE Feb 28, The Post Intelligencer will say tomorrow in a copyright story that Alfred M. Hubbard, Seattle youth, was probably the discoverer of at least the principle of the "free energy" motor privately demonstrated in Detroit last week.

In 1918 Hubbard, when only 18 years old, demonstrated an apparatus by which he claimed extracted its electric energy directly from the air. Today Hubbard declared he believed the motor demonstrated in Detroit by Lester J. Hendershot is a development of his apparatus.

In a demonstration here in 1918, Hubbard propelled an eighteen foot motor boat equipped with a 35 HP electric motor apparently getting its power from a coil 11 inches in diameter and 14 inches long.

The New York Times
February 28, 1928

EXPLAINS MAGNET IN FUELLESS MOTOR

*Hendershot Says Shifting Its Field to East and West
Causes Rotary Motion*

Winding of Magnet Secret

*Inventor Asserts Engine Weighs about 4 Ounces Per Horsepower
Expected Here Today*
Special to the New York Times

PITTSBURGH Pen. Feb. 28. Initially indignant because the manner in which his fuelless motor gains its power had been misrepresented in dispatches from Detroit and Washington, Lester J. Hendershot today stated there was nothing mysterious about his motor that the force that energizes it is the "same force that pulls the needle of the compass around, and there is nothing mysterious about that".

The fuelless motor was not his objective, he explained, at the time he began his experiments some three years ago, when he first became interested in aviation.

He soon learned that "the ultimate development of aviation depended largely upon the discovery or invention of an absolutely true and reliable compass," he explained, "The ordinary magnetic compass does not point to the true north - it points to the magnetic north, and varies from the true north to a different extent at almost every point on the earth's surface."

"There is another compass, the magnetic induction compass, that indicates the true north. But it must be set before each flight, and is not always reliable."

"I found that with a pre-magnetized core, I could set up a magnetized field that would indicate the true north, but I didn't know just how to utilize that in the compass I set out to find."

"In continuing my experiments, I learned that by cutting the same line of magnetic force - north and south, I had an indicator of the true north, and that by cutting the magnetic field, east and west, I could develop a rotary motion."

"I now have a motor built on that principle that will rotate at a constant speed, a speed predetermined when the motor is built. It can be built for any desired speed, and a reliable constant speed motor is one of the greatest needs of aviation."

The main secret of Mr. Hendershot's invention, his friend, Barr Peat declares, is, "the method of winding a magnet in the motor so that it will rotate in the opposite direction than the earth revolves." He says there is no heat, because magnetic forces are cold and the motor is stopped only by breaking the magnetic field in the windings. The magnet in the motor, he thinks probably would have to be recharged after about 2,000 hours of operation.

Mr. Hendershot declares that one of his motors, complete and ready to be installed in an airplane, would weight little more than four ounces for every horsepower it developed, while the best of the gas engines now built weighs about two pounds per horsepower.

Mr Hendershot says that altitude would not affect the efficient operation of his motor, for the magnetic influence of the earth has been found to remain the same as high as man has ever reached.

He said the same principle which made his original model operate only when it was placed in one direction - north and south, will be developed so that it will provide a compass that will always indicate true north.

Lester J. Hendershot inventor of the "fuelless motor" or self-driven generator or electrical, energy collector, nobody seems to know quite which, is expected in New York today to dissipate some of the mystery surrounding his machine. It has aroused a good deal of skepticism among men who have dealt with electrical energy all their lives, and among physicists who do not believe that the law of the conservation of energy has been repealed.

However, Major Thomas Lanphier, commander of the First Pursuit Group at Selfridge Field, Henry Breckinridge attorney for Colonel Charles A. Lindbergh, and D. Barr Peat, a friend of Mr. Hendershot, are just as confident that the inventor has stumbled on something which may be capable of development into a revolutionary power source.

Whether the machine has yet arrived in the City, Major Lanphier would not say, and he said yesterday that he did not care to say anything more about the motor until Mr. Hendershot arrives. He did deny again, however, that Colonel Lindbergh had any interest in the machine aside from his examination of it while at Selfridge Field.

The New York Times
March 1, 1928

HENDERSHOT FAILS TO COME

Guggenheim Fund Disclaims Connection With "Fuelless" Motor.

Lester Hendershot inventor of the so called "fuelless" motor, didn't appear in New York yesterday although it had been reported that he was on his way here. At the office of the Guggenheim Foundation it was said that they had not heard from him, and later issued the following statement.

"During the last few days newspaper reports have mistakenly connected the name of the Daniel Guggenheim Fund for the Promotion of aeronautics with a reported invention of an electromagnetic motor. The fund has no connection whatever with this enterprise. Some months ago the reported invention was submitted to certain members of the fund for their consideration, but the fund was unwilling to take any action in regard to it until it had been extensively tested."

THE NEW YORK TIMES
March 2, 1928

SHOWS EARLY TYPE OF FUELLESS MOTOR

Hochstetter Exhibits Previous Invention by Hendershot at Which He Scoffed

PROPOSES TEST OF ENGINE

If New Device Stops in Shielded Box Says Critic, He Will Admit It Is Wonderful Discovery

Frederick Hochstetter, head of the Hochstetter Research Laboratory of Pittsburgh New York, yesterday exhibited a model of a motor which he said, Lester Hendershot inventor of the so-called "fuelless" motor, had invented several years ago and for which much had been claimed, but not proved. This was the model, Dr. Hochstetter said, which had concealed in tubes small batteries which actuated it instead of the magnetic currents of the earth, which the inventor contended was its motive force.

Mr. Hochstetter set up the model in a room of the Waldorf and expounded at length his technical reasons for asserting it would not work. He was accompanied by E.H. Wicks, a Pittsburgh attorney, and Lloyd Wheeler, an engineer from his laboratory. He also said that he represented the view of a committee composed of Dr. L.P. Seig, dean of the graduate school of the University of Pittsburgh, Dr. W.R. Worth, director of electrical engineers at Carnegie Technical Institute, G.F. Dilling, a Pittsburgh engineer, R.H. Brownlee and H.O. Swaboda of Pittsburgh.

It was this model, Mr Hochstetter said, which Hendershot had exhibited in Pittsburgh. It was never developed, Hochstetter said, and Hendershot never revealed the principle by which he contended it worked, although the inventor had signed an agreement to explain it to Hochstetter. He challenged the inventor to test it on his newest model by enclosing it in a shielded box, which would intercept any ordinary electrical current in the atmosphere and if it stopped after it were shielded he said he would be willing to admit that Hendershot had a wonderful invention. Otherwise it is not.....(end)

Hendershot himself was not to be found yesterday, although it was reported from Washington that he had started for New York from there.

NEW HAVEN Con. March 1 - The Hendershot "fuelless" motor, is amazing as an experiment, but a fluke from the standpoint of electrical engineering, declared W.B. Hall, Assistant Professor of Electrical Engineering at Yale, today.

The hesitancy of the inventor to permit the motor to be investigated by experts because, as he has put it, he desires to protect the rights to a patent, indicates that there is something wrong with the invention, Professor Hall said.

The New York Times
Wed. March 7, 1928

MOTOR RUN BY ION ENERGY

Jesuit Inventor From Brazil is Here to Market Production,
Now Undergoing Patent Tests.

NOT A FUELLESS MACHINE

*"Inter-Atomic", Force Increases Electric Battery Power, He Says,
Doubts Hendershot Claims*

An Italian Jesuit priest from Brazil announced here yesterday that he had invented a motor that makes use of "interatomic" energy to generate many times the power it receives originally from an electric battery. The motor is now at Washington, where it is undergoing the Patent Office investigation.

The priest is the Rev. Antonio d'Angelo, S.J., a stocky, earnest little man who combines missionary work in Brazil with tinkering in his own electrical laboratory. He speaks no English, but told of his machine through his brother, Biagio d'Angelo of 1,475 Leland Avenue, the Bronx.

Father d'Angelo became interested in electricity twenty years ago when he was a student at a Jesuit seminary in Naples. A year and a half ago he was sent out by his Order to Brazil to carry on missionary work at Ribelrao Preto among the Italian immigrants. He had to get a special dispensation from Bishop Alberto Gonzales of Ribelrao Preto to visit the United States, where, so his brother had written to him, fortune comes more easily to the man with a new money-saving device. He came here in November, 1927, and hassix months.

"I challenge any one," he said yesterday, "to use the magnetic field of the earth for running a motor. The energy from that would be too small."

His motor, he said, could be used in the home to supply electric lighting cheaply, and even heating. He said that it could be used to run trains, airplanes and automobiles.

Father d'Angelo had a plan of his motor with him yesterday. He showed how it started to develop energy from an electric battery and how this original impulse worked on the machine to generate many times its power through the "electricity produced by the interatomic energy of the ions".

The New York Times March 10, 1928

2,000 VOLT SHOCK FROM HIS FUELLESS MOTOR Paralyzes Hendershot During Experiment

WASHINGTON March 9 - Lester J. Hendershot of West Elizabeth Pa. Who became famous overnight as inventor of the so-called "fuelless " motor after Colonel Charles A. Lindbergh inspected the machine, is a patient at the Emergency Hospital recovering from temporary paralysis. It was caused by a severe electric shock sustained while experimenting with the motor here in the Washington Loan and Trust Building, Ninth and F. Streets.

The accident occurred about noon Tuesday, March 6, when, according to statements at the hospital tonight, its ambulance was summoned to the Loan and Trust Company's building, where Mr. Hendershot, it is declared, was found in a temporarily paralyzed condition. A physician at the hospital stated that Mr. Hendershot had been rendered unconscious by the shock and that he did not recover until about 6 o'clock Tuesday afternoon.

The electric shock, it was stated at the hospital had temporarily paralyzed Mr. Hendershot's legs, arms and palate for several hours, and while his condition was today still described as serious at the hospital, it was added that he had greatly improved, although he could not be discharged for several weeks. Only two of his close friends have been allowed to visit him at the hospital.

At the hospital, where he is a private patient, it was stated by one of the staff physicians, that no information could be given beyond the understanding of that physician that Mr. Hendershot was injured while working around his motor, the shock being caused by 2,000 volts passing through his body.

First information that Mr. Hendershot had been injured in Washington came in inquiries from friends in Pittsburgh, came as a distinct surprise.

Mr. Hendershot and J. Barr Peat, his associate, have been in Washington for nearly a week, conferring with a patent attorney and it is understood, also with Major Thomas G. Lanphier, commander of the First Pursuit Group at Selfridge Field, Michigan, and with Colonel Henry Breckinridge, legal adviser to Colonel Charles A. Lindbergh.

PITTSBURGH March 9, - If Lester J. Hendershot has been seriously injured by an electric shock in Washington, as reported from that city today, neither his mother nor Mrs. Hendershot had received word of it, his mother said this afternoon, when inquiry was made at the Hendershot home in West Elizabeth, as to the extent of the inventor's injuries.

The New York Times November 12, 1928

MAY SEEK MOTOR PATENT

M.C. Kelly to Ask Five Scientists to Test Hendershot Device

PITTSBURGH Nov 11 Fed. Representative M. Clyde Kelly of Pennsylvania. It became known here today, plans to seek a Congressional Patent for the "fuelless" motor of Lester J. Hendershot of West Elizabeth Pa., if five scientists approve the invention as practical. A Congressional patent gives the patentee full protection for seventeen years.

Hendershot's invention, which he describes as a "magnetic induction" motor was first announced in March. At that time in some quarters it was regarded with skepticism.

The motor, according to its inventor is without visible means of power. It obtains its initial impulse, Hendershot maintains, from a pre-energized magnetic core, and its secondary and greatest power pulse by magnetic induction, from the earth.

Hendershot today said several of the motors had been built here, and the last one, which developed sixty horsepower, had been in operation constantly for two weeks without re-energizing the magnetic core.

THIS APPENDIX COVERES VARIOUS BOOK REFERENCES & MAGAZINE ARTICLES

AMAZING STORIES MAGAZINE September 1946

There is an article on Hendershot appearing in this magazine, but I have not been able to locate a copy.

“WILD TALENTS” by Charles Fort

The article in Chapter 32 of this book examines the published data and adds nothing new worth quoting, other than the following comments:

“If the thing were a fraud, it would seem that it would have to be obviously a fraud”

“FLYING SAUCERS UNCENSORED” by Harold T. Wilkins

This article also examine the published data with nothing new to add.

THE HENDERSHOT MOTOR MYSTERY by F. D. Fleming Printed in FATE, Vol. 3. No. 1, January 1950

This article contains no new information, being just a story compiled from the other references contained within this and the previous Appendix. I have therefore not included the text.

THE SO-CALLED HENDERSHOT MOTOR

by Gaston Burrige

Article published in *BSRA Round Robin*

Vol XI, No.6, March-April 1956

For more than 25 years, Lester Hendershot and "The Hendershot Motor" have appeared to be an enigma wrapped in an obscurity tied with a contradiction. They still are. Most people are surprised to learn that Lester Jennings Hendershot is alive. He is very much so. Not only is he actively alive, but at 57, he is deep in his experiments with his device - a device which has come to be erroneously known as a "motor". To call Hendershot's mechanism - or "electricism" - a "motor", only adds to the enigma. Long ago, it was termed by a most orthodox scientist, "more properly a generator than a motor". Somehow, "generator" never caught on. It has always been "The Hendershot Motor". Probably, it will remain so. In addition to generator, the arrangement may be properly called an apparatus, a system, or a device.

It seems to me it would be quite incorrect to say Hendershot deliberately created the enigma. It would also appear wrong to say he has ever done much to help clear it away! The enigma has suited Hendershot's purpose because he does not *know*, he says, *what* he has! He does not know, he says, *how* it works. Neither does he know, he says, how to duplicate it consistently, or in different sizes. "I am not one of these slide-rule boys," he told me. "I don't know how to figure these things out first. It is pretty much a "cut and try" proposition with me."

Whether Hendershot knows what he is doing or not, he has evidently created "a something" which has seemed interesting enough to others, for they are, at the present time, seeking to duplicate his accomplishments. I know of one such effort being attempted in New Jersey, another in the Bay region of California. Whether either of these will "beat Hendershot to the Patent Office" remains to be seen. Whether a patent will truly protect such a device or not is highly problematical. While it might certainly prevent large scale outside manufacturing and *sale*, it most certainly would not prevent private or individual manufacture and *use*! Of course, our patent laws do protect - in *theory* - against individual duplication of any patented article, but - in practice - it is quite impossible to accomplish such protection. Once anyone has learned how to tap a *basic* source of energy for his private use, and sets the knowledge forth in a patent - which he must do to obtain it - the world will not beat a path to *his* door, so much, as to the door of the Patent Office, for there they can learn the secret for 25¢. Sooner or later, every inventor of such a device comes to realize this fact. He is thus between two fires. Both are equally hot. Either is bound to consume him sooner or later.

This, I believe, is why so many of these systems have died with their inventors. Few men have learned - perhaps it is impossible for them to learn - that he who gives most, receives most. All of us are too close to the jungle for such thinking. However, denying a truth does not obliterate it.

What makes up a Hendershot "motor"? There are some basket-woven, flat coils of insulated wire. These, no doubt, are inductances of some sort. What is the size of the wire or how many turns of it on each "pancake" there may be, Hendershot does not say. There are some stainless steel rings - "non-magnetic" stainless steel - and some pieces of "stick carbon". There are some short lengths of "Alnico" or equivalent, permanent magnets. There may be - and probably are - some electrical condensers among this plethora of parts, but Mr. Hendershot does not say, nor are their capacities hinted at. Too, there may be other accoutrements well hidden from prying eyes. I would be surprised if there were not! It would appear there are no moving parts which deliver the power, hence the lack of any true resemblance to a motor. The device manufactures an electrical current which Mr. Hendershot told me would power either an electric motor or light an incandescent lamp. In fact, he has pictures of himself holding the device in one hand and a lighted bulb in the other. He also has pictures of the device placed on a pile of lumber, and a lighted lamp above it.

There also appears to be within this device some very critical features. For instance, as Mr. Hendershot told me, "Sometimes, I wind on too many turns of wire. Then, the thing won't work at all. I take some of the turns off. Maybe it works, and maybe not. If it works it soon burns out. That is my greatest trouble - the things burning out." One immediately wonders if it is possible the potential of the power *source* changes frequently?

What powers the Hendershot device? If Mr. Hendershot knows - even has any idea - he hides the knowledge well. He says he doesn't know. He also hastens to comment that any scientist who has watched his apparatus in operation, doesn't know either! He does not name any scientist who has watched his device in operation. The common explanation of the source of its energy has been from "the magnetic lines of force of the earth". If such is the source, Nikola Tesla, the great electrical inventor, once commented, "such a force would have to be measured in 'mouse-power'".

There are two other possible sources. One is earth electricity, the second, atmospheric electricity. It was Tesla himself who established there were such charges in each. He learned the earth's charge was positive, the atmosphere's, negative. Tesla also learned Nature has a means of maintaining the earth's full charge continually. If he ever satisfied himself *how* this was accomplished, it remains one of his many secrets.

There is a possibility the earth may be an "electro-magnet", rather than a permanent one. If so, there is also a possibility its power could be considered above the "mouse" classification. Dr. Edward C. Bullard of the National Physical Laboratory in London, presents a theory accounting for the earth's possible electro-magnetic field. Briefly, Dr. Bullard says the earth's liquid or semi-plastic core is highly radioactive. This radioactivity generates enough heat so motion in the form of convection currents is set up. These currents provide the "excitement" necessary to make electro-magnetism a possibility. Thus, in theory, at least, there are possibilities of a source of power to operate Hendershot's apparatus. It may well be, while its potential is theoretically great, like the power from the sun, its actuality is small. It is also possible, while its potentiality is great, the cost of collecting it or converting it, is also great, because our present methods of using energy are so crude. We seem to waste much more than we use. As yet, we have not overcome the "friction of use!"

Someone has said, "point of view is everything." Well, if not everything, then a great deal. Digging out "facts" is often dependent upon the tint of the lenses in one's glasses. Here is what I mean. Early in Hendershot's experience he was taken to Detroit's Selfridge Field to demonstrate his "motor" to Major Thomas G. Lanphier, Commandant of the Field. The Major was interested in the device, but never claimed any sponsorship of it. Shortly, Detroit newspapers carried stories that the technicians at the Field had constructed a device under orders of Major Lanphier and under instructions from Hendershot. This motor *worked* according to press releases of that day.

Being interested in this point, after considerable difficulty, I located, now Colonel and retired, Thomas G. Lanphier. In answering direct questions from me, Colonel Lanphier informed me that no Hendershot device of any sort was ever constructed at Selfridge Field under Hendershot's instructions while he, Lanphier, was Commandant. Lanphier said, "The only device ever at the Field was one which Hendershot brought to the Field - and it was proved a fake at an eastern University laboratory."

I laid this information before Hendershot. He remarked, he could not understand it at all, because the device *was* built at the Field, by Field technicians. That he, Hendershot, did not even so much as wind a single coil of it. That the completed device did work - just as the newspapers had reported. Thus are enigmas built!

A Washington, DC, newspaper carried a story on March 9th, 1928, relating Hendershot was recovering in a Washington hospital from a 2000 volt shock sustained while demonstrating his device in the office of his patent attorney, presumably to interested capital. I have in my files a letter from a newspaperman, along with one of the leading Pittsburgh daily papers, which states Hendershot was not taken to the hospital for any such treatment at all, but for a lunacy test. Strange as it may sound, Hendershot was not found "guilty", and was released. One is often quite surprised at the tip of Justice's scale!

Whether Hendershot's device is ever developed to a point where it is, or can be, understood and used for 'everyday purposes', both he and it will always be 'between covers'. This came about through Charles Fort having devoted several pages to Hendershot in his book, "Wild Talents", last chapter (32). Fort doesn't "plug" very hard for Hendershot, but does bring up several points which might otherwise be overlooked. I asked Hendershot if he had seen that which Fort had written about him. Hendershot replied that he had. As Hendershot answered several other questions relative to the publication, I thought I noticed a bit of impatience both in his tone of voice and general attitude. This indicated to me he was not overly pleased with the words he read.

The January, 1950 issue of "Fate" magazine carried a story of Hendershot. My investigations lead me to believe this story was based upon the account in the Fort book along with those of several newspapers published in 1928. When I brought this story to Mr. Hendershot's attention, his reply to my questions were evasive. I gained the feeling that Hendershot knew Mr. Fleming, the article's author, but for some reason was displeased with either the piece, or the results *accruing* from it. There may be an interesting story lying buried here!

In the May, 1953, issue of "Fate" magazine appeared an advertisement from the "Utility Engines" professing to have plans for sale of a so-called Hendershot motor for \$2.50. Suddenly, all mail was rejected by the address of the "Utility Engines"! I asked Hendershot about this matter. He told me he learned of it soon after the advertisement was published. Soon after that he learned about the plans they were selling and using his name. They were doing this, Hendershot claimed, without his permission or consent. He told me that he promptly informed the postal authorities of this circumstance. "They must have done something about it, for I heard nothing more about them," he said. Hendershot was quite emphatic to me regarding the plans put out by the "Utility Engines" *not* being of his device. He was so emphatic, in fact, I felt he, like the maiden, "didst protest too much". Thus, 'the ol' hound dog's nose' went to the ground! In due course it came up with the information furnished by an acquaintance of Hendershot's to the effect that Hendershot had remarked at the time, while the "Utility Engines" information was not his device, "it was pretty damn close!"

I have had the "Utility Engines" material before several competent radio and electronic men. They say the diagram of connections are definitely within the radio band of frequencies. They comment that the device would undoubtedly work - *if* close enough to a powerful radio transmitting station and stated "We find nothing original existing in the circuit or in the arrangements of components". I also know of several who have been trying for months to "make something out of the prints", but so far, have failed to do so. These men are trained in electronics and radio techniques. If the plans are as close as indicated by Hendershot's remarks, some one may "stumble" across the right answers. Who knows?

The afternoon I met Hendershot he was in his front yard taking some pictures of his young sons with a new Polaroid camera. I am pretty sure the camera was new, because the pictures were not turning out well. Hendershot is a rather short man, balding somewhat, and is a rather rotund build. His eyes are dark brown, alert, and at time piercing. He seldom smiles. When he does smile it is a wan smile, and not very generous in amount. Hendershot gestures a great deal with his hands, and shakes his head negatively often. I felt he distrusted me greatly. This became more evident as I laid before him more and more of the information I had. Many of my questions Hendershot refused to answer point blank, referring me to his attorney. When these same questions were laid before his attorney, the attorney also refused to answer them. Why, only time will tell. I think I know.

Probably, there is "something to" the Hendershot device, or any other of its nature. Whether that "something" is of great potential or not, remains to be seen. Fantastic amounts of energy lay all about us. Mankind seems only to have learned to use energy in huge quantities, wasting most of it. The more "civilized" he has become, the greater his energy use - and waste. It is quite evident, if he continues to multiply and continues to require more energy, he will have to look for it in some new places, or entirely revamp his machinery. There appear certain basic dangers for man along the pathway of using atomic energy - dangers of processes and uses getting out of hand, thus blowing himself and his planet to Kingdom Come. There may be as many dangers along the pathways of earth electricity, electro-magnetism, atmospheric electricity, or solar power, but somehow I have a feeling there are not. Everything we have, everything we know, was put together once. As far as we have learned, the putting together process has consumed considerable of that which we know as "time". Perhaps "hurry" has been the tune of the piper - and we haven't asked the price!

THE HENDERSHOT MOTOR RIDDLE
BY Gaston Burrige
Published in "FATE" Magazine 1957
by Clark Publishing Co. III. USA

(This article is basically a rewrite of the earlier article in Round Robin transcribed above, but written in the second person and with a decidedly more negative flavor towards Hendershot. To avoid duplication, I have only included extracts in this article that were not presented in the previous text.)

In reference to Hendershot's accident:

"In a recent letter Mr. George Swetnam, long associated with The Pittsburgh Press and considered by some to be an authority on early Hendershot matters, writes, 'The story died suddenly, behind a curtain of red faces. It was a lunacy test, not any 2000 volt shock, that took Hendershot to a hospital. He wasn't a nut, but because of the desire to escape publicity he wasn't prosecuted.'"

In reference to the components of the Mark III device:

"The Hendershot device consists of some basket-woven FLAT coils of wire. There is a relationship between the distance these coils are placed apart, the number of turns wound on them and the size of the wire. There are some stainless steel rings about three inches in diameter....."

In reference to coil burn out:

"If I don't get on enough wire, the job soon burns out - sometimes in a few minutes, other times in a few hours."

In reference to Dr. Hochstetter:

"Soon after the story broke..., a Dr. F. W. Hochstetter, reportedly the director of a research laboratory in Pittsburgh, sent the following telegram to Major Lanphier and others in Detroit. 'Before committing yourselves to any statement in reference to the Hendershot motor, please communicate with the undersigned or W. C. Trees of this city, as we have had some negotiations with this man on what appears, from newspaper reports, to have been the same thing he is now seeking to promote and which proved worthless.'"

"Mr. Swetnam indicates that a model torn down at a Pittsburgh laboratory (Hochstetter's?) very cleverly used the innocent looking screws which appeared to hold the device to its wooden base, for binding posts! These carried outside current into the device."

"The Detroit Free Press carried a story, date-lined Pittsburgh, to the effect that Dr. Hochstetter's attorney, Mr. E. H. Wicks, displayed to newsmen there a contract said to have been signed by Hendershot and an associate, (Peat?) which covered the sale of an earlier model of the Hendershot device to J. C. Trees and W. L. Benedum. The amount mentioned in the contract was \$150,000, of which Wicks claimed, \$25,000 had already been paid to Hendershot and his co-worker. Hendershot denied categorically knowing either person."

A STORY OF FREE ENERGY**by Ed Skilling****Published by Journal of Borderland Research****Vol. XVIII, No 5 & 6. July /August 1962****And republished in a modified form
in ENERGY UNLIMITED #13**

(The version reproduced here is from Borderland Research 1962, being a more comprehensive version)

On a warm July evening 1958, a telephone call from a friend and business associate startled me. The gentleman, an orthodox scientist, Dr. X to protect his identity, who had obtained his Doctorate at Columbia University, asked me to see a free-energy device in which he had just invested considerable capital for a three month option to buy a 50% interest.

After signing a secrecy agreement I met with Lester J. Hendershot and saw the Hendershot Motor. Dr. X chose to rename it the Hendershot Fuelless Generator, which was more descriptive of the device.

Les Hendershot in his sixties was a simple, sincere individual with a lovely wife and four wonderful children. I had expected to meet a fast talking con man who, I thought, was about to take my friend for his money.

The story of the Hendershot Motor as it was called in the late 20s can be found in Charles Fort's book "Wild Talents" and in the files of the Detroit "Free Press" and the New York "Times". "FATE" Magazine carried an article on it by Associate Gaston Burridge in January 1950 (*Burridge's articles came out in 1956&57. It was Fleming's article in Jan 1950 - See this Appendix*). The Fate article renewed interest in the unusual device, much to Hendershot's sorrow, as he was plagued by all sorts of people from business investors to weirdo religious fanatics who accused Les of causing earthquakes, floods and famine.

The unit that Dr. X had seen operated with a power output of 300 watts was partially disabled when I first saw it, due to Dr. X's insistence on seeing the manner in which the coils were assembled. My part in the program was to duplicate the unit and attempt to produce power in the same manner. To save time we were to rebuild the disassembled coil and try to get it working again as well as build a duplicate model. My only interest was academic so there was nothing to lose but my sanity.

Several days later, after much sweat and frustration, the original working model and the duplicate unit were assembled and wired to the schematic drawing I made from the original wiring. Strangely enough, I learned that I was the first to make a true schematic using electronic symbols rather than picture diagrams.

Les Hendershot was a clever man with his hands but was not an electronic technician. His knowledge in the field of electronics was learned by tinkering with radios, and either he did not know how to construct an original diagram or he didn't choose to, due to his desire to maintain secrecy. Dr. X and I attempted to get the original unit working in my lab without success. We returned to Hendershot's home for further consultation and experimentation. Several hours after arriving at Hendershot's home at about 2 AM the 75 watt light bulb we had placed as an output load flashed once. This incident encouraged me onward and it was a lucky chance that it did flash as I would have left the project and filed it away as a hoax. It was not until October 26, 1958, four months later, that I saw a real demonstration of electrical phenomena. Many tests were made between July and October of that year and much investigation to determine the principle involved in the circuitry was carried out. To make a long story short and to save retelling of countless details involved in my experience since 1958, I can say that I know of no one person other than Lester Hendershot who has been able to make a Hendershot generator produce power. Many people have seen demonstrations in many places and at many times, including Mexico City. All have failed to duplicate Hendershot's electrical phenomena.

I have my own pet theories on what principle is involved but have been unable to accept the theory of many who feel that Hendershot was an undeveloped psychic who under certain conditions could produce this ability. My conclusion was reached by means of logical analysis.

Many times in the past and certainly in 1958 while Hendershot was away from his home working, his children were able to turn the unit on and operate a floor lamp and television set in the family living room without Hendershot's conscious knowledge that the device was producing power.

Until it can be proved otherwise, I shall continue to investigate and experiment with ideas based upon my own conclusions. Lester Hendershot died in April 1961, and if there was any known secret to his ability he could not tell us directly.

I have never read or heard tell of any gainful results obtained by means of contacting the departed through mediumship. Much philosophy but little useful technical information can be had in this manner, at least in this writer's opinion. For what it is worth to technically inclined Associates, the details of construction will be revealed now to BSRA., I'm sure others can obtain some results such as occasional shocks from charge build-up in the unit and minute indications of power which is all I could produce. It may be that some one can duplicate Hendershot's ability.

PART 2

This man, Lester J. Hendershot, was an amazing individual when compared to men with technical abilities acquired by formal education. His native intelligence was extremely high. Charles Fort was certainly correct when he included Hendershot among the rare individuals that have Wild Talents.

His ability to perform technical feats by intuition was developed to a high degree. As an example: If he wished to build an electrical coil that would operate in a circuit at a resonant frequency of say 500 KC he would go to an electronic supply store, pick out a spool of wire from the supply racks, take it home and wind a coil on a form which would turn out to measure in a resonant circuit, 500 Kilocycles. He was able to consistently achieve this phenomena, and as a result of it created a fuelless generator that would produce electrical power.

When compared to T. Henry Moray, Hendershot in my opinion was a giant.

The Associates reading this Free Energy Story will learn that Hendershot duplicated the same electrical phenomena that Moray did with far simpler components. Hendershot did not require a secret, exotic type of ionic cold cathode tubes as valves and oscillators which Moray claims is the secret behind his Radiant Energy.

This writer's experience working with Hendershot combined with what is published in Moray's book "The Sea of Energy in which The Earth Floats" leads one to believe that the energy field tapped by these unusual men is one and the same. Both men appear to have suffered similar problems in trying to present to the world, Free Energy. It is most unfortunate that Lester Hendershot did not live to meet T. Henry Moray, as the combination of the Hendershot simplicity of circuitry with Moray's knowledge and theory of Radiant Energy would astound mankind.

Lester J. Hendershot was of the opinion, as expressed to this writer in 1958, that his Free Energy device, the Hendershot Generator, was tapping a magnetic force field. Examination and study of the components used in the Hendershot circuit does not substantiate a magnetic theory.

Tests of the circuit in a strong magnetic influence would not induce a voltage in the circuit that would produce power. After exploring various facets of magnetic fields in an attempt to induce power into the device, the search was abandoned. A great deal of study was made in a search for a theory that would fit the components used in the device. The electrical parts used in the Hendershot circuit, such as: capacitors, coils, transformers, magnets, solenoids, were studied on their individual merits to determine their function in the circuit wiring. Measurements in the static condition were made of the non-commercial items to determine component values.

BASKET WEAVE COILS

The unique feature of the Hendershot device is the basket weave coils, with cylindrical capacitors built in the centre of the coils. (See A & B Fig. 1). Hendershot did not explain his intent when he designed this part of the circuit. In the early days of his experience, during the late 20s, he used standard broadcast radio coils which he could purchase in the radio supply stores of that era.

A test of the present coil design on a radio frequency resonant bridge or "Q" meter will reveal that the coil out of the circuit will be self resonant in the lower frequency of the radio broadcast band of 500 KC. This indicates that Hendershot kept the present design in the same ratio of inductance that was used in the early days.

Schematic Figure 1

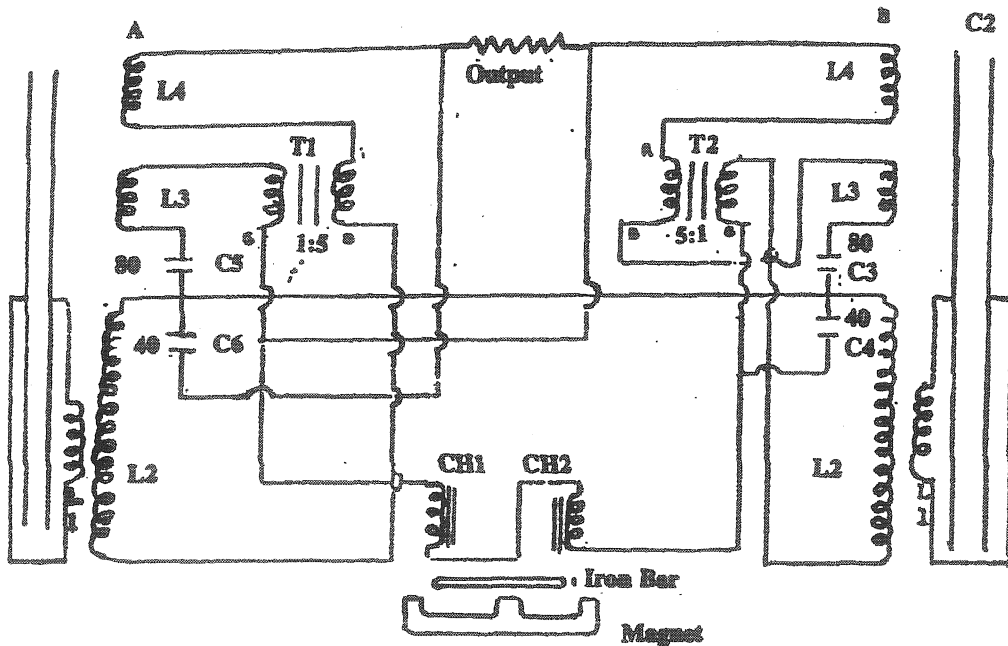

Another interesting component is the solenoid coils CH1 & CH2 used in conjunction with a magnet from a radar magnetron with a soft iron bar between the magnet and the solenoid coil cores. During operation of the Hendershot Fuelless Generator, this unit will buzz at a frequency rate dependent upon the air gap between the magnet, iron bar and coils.

The magnet-coil device was mounted in a frame so that a screw adjustment would move the coil in relation to the magnet, varying the air gap which varies the resonance of this "buzz" frequency. Like the basket weave coils, A & B, the magnet-coil device idea was derived from a telephone receiver used in the early days. A regular buzzer used in a door bell annunciator should serve the same purpose. Hendershot purchased the solenoid coils in a radio supply store and they appeared to have been used in a 110 volt bell ringer.

The two commercial transformers, also purchased from a radio supply store were vertical oscillator transformers used in a TV set and were of unknown make or brand. They have a 5:1 turns ratio. Hendershot used several different types of transformers in the circuit but found the TV ones worked the best. Two dual electrolytic capacitors C3, C4, C5 and C6 are standard Pyramid TM 58, 40-80 MFD at 450 working volts.

Two additional capacitors are required for C1 and C2. The hand wound capacitor used in centre of the basket weave coils are also made from Pyramids TM 58. Coils A & B are identical in construction so only one will be described. The coil is cylindrical, 5 15/16 inches diameter (See Fig. 2). It is wound like a basket around fifty-seven 1/8 inch diameter wood dowel pins three inches long. The dowel pins are even spaced on the circumference of the circle. All coils are wound in the same direction, weaving in and out between dowel pins mounted in the same type base to hold them rigid.

Starting at the base, L2 is 64 turns of No. 24 gage copper enamel or Formvar wire close wound. L3 and L4 is Belden thermoplastic hookup wire No 20 gage, a 25 foot spool is required for each coil L3 and L4. 25 feet will end up with 24 turns wound in the same fashion as L2, close wound. Hendershot always used L3 yellow and L4 red for easy identification.

L1 is made from No 28 gage copper enamel coated or Formvar magnet wire. 14 turns close wound over the outside diameter of L2 in the centre of L2. Plastic electrical tape is wrapped around L1 to form a smooth surface for winding, after winding the 14 turns, wrap additional tape to hold L1 in place.

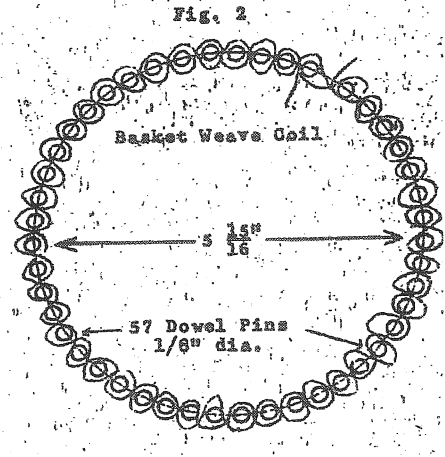

The Capacitors C1 and C2 are the most difficult to build and are the critical key item to success or failure in producing results. The foil from two capacitors, Pyramid electrolytic TM

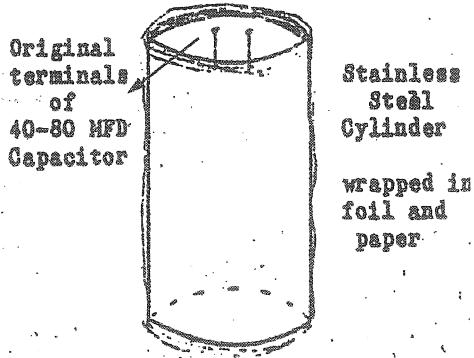

58, must be removed from the can that encloses the foil by cutting the top or bottom off with a hack saw or other cutting device. The coiled foil is removed from two capacitors and spread out on a flat table. A TM 58 capacitor should measure, including foil and paper, 91 1/8 inches long and 2 3/4 inches wide. Wipe off excess electrolytic solution so that it is dry. One side of the paper holding the foil will be full length, the opposite side will be split with terminal connections appearing at each end of the split portion. The capacitors that were used in the early experiments had a gap between the split foil of 3/4 of an inch.

Prepare two cylinders of metal with dimensions of 5 1/4 inches in diameter by 2 3/4 inches wide. A stainless steel sheet metal 0.032 inches thick was used in Hendershot's cylinders, open at both ends. Before wrapping begins, insulate the cylinders with pure kraft paper. Ordinary brown wrapping paper is unsatisfactory as it contains impurities. Wax paper might be used as a substitute.

It is interesting to note that Hendershot originally used one pound coffee cans for the capacitor cylinders but found that after a period of time the electrolytic left in the capacitor paper would produce perforations in the metal, rendering the cylinder useless. This is why he made the later cylinders of stainless steel.

After insulating the cylinders, wrap the capacitor foil and paper around each of the cylinders. Start at one end with the long unsplit foil on the inside and wrap the full length onto the cylinder. Secure the wrapped capacitor with a string or tape so that it will not unravel. Both units should now look the same.

Each of the completed capacitor cylinders C1 and C2 are placed on the inside diameter of Coil A and Coil B. After centering the cylinders, pour melted paraffin into the outside diameter of the cylinder and inside diameter of Coil A and Coil B. The melted paraffin will run into the turns of the wire sealing the complete units. If the correct tensions were applied while wrapping the capacitor paper and foil, the measured capacity should be 0.0078 MFD.

It is very difficult to obtain the correct capacity and this process may have to be repeated many times to arrive at the right value for each unit. Short circuits of the capacitor will render the results useless and of course make it impossible to measure the resultant capacitance value. For accuracy the capacitors should be measured with a reliable capacitor bridge. Hendershot was able to accomplish this feat intuitively.

If all conditions of the circuit are met with the proper component values and if the wiring is made according to the schematic diagram, the unit should function and produce 300 to 500 watts of energy. The only limiting factor to the amount of power that can be extracted is the wire size used in the coils and transformers. Hendershot on many occasions when applying excessive output loads, would burn up the unit by the overheating of the wiring. Some variations can be made in the circuit wiring but what changes are tolerable are unknown.

UNKNOWN CHARACTERISTICS

After a unit was wired either by Hendershot, or other experimenters he would sit down at the device with a length of insulated wire bared at each end and begin making connections to various terminals of the unit until the solenoid-magnet combination would buzz and the output load, if it was a standard 110 volt light bulb, would glow. He then would adjust the air gap between the magnet and solenoid coils until full brilliance was achieved and the buzzer produced a steady tone. This procedure would take from a few minutes to several hours.

On one occasion he adjusted the unit for 10 to 15 minutes and only achieved a flash of light from the output. Several hours later he found it necessary to rebuild the capacitors before any further tests could be made. Either the unit would work immediately or not at all, depending on the unknown characteristics of the phenomena.

It may be noted on the schematic that capacitor C6, which is one half of a dual Pyramid TM 58, the positive terminal is connected to one side of the output load. This connection places an electrolytic capacitor in an AC circuit. A polarized capacitor will not work in an alternating field and will overheat. The schematic diagram as shown in Figure 1, did operate for ten to fifteen minutes before the capacitor began to boil and blow out. If an experimenter should be fortunate enough to achieve success in producing power it may be advisable to connect this capacitor the same as C4.

Experimenters who have worked with Hendershot may have other circuit diagrams that also produce results, but this story has been this writer's experience in a true story of Free Energy Phenomena.

ENERGY UNLIMITED**A Case for Space**

by

Arthur C. Aho

Printed by

South Antelope Valley Publishing Company Littlerock, California
1968

(This transcription contains only text that relates to Aho experience with Hendershot)

Some years ago Aho was involved in a science experiment which proved to him beyond a doubt that an unlimited energy source does exist and that it can be tapped.

He has postulated a basic theory to explain this energy and he feels that he is on solid ground in taking a stand to reevaluate and extend certain basic theories in use today. He feels this because, in addition to many years of private study and research, he was involved in experiments with Lester Hendershot in building, operating and evaluating certain devices which generate electricity in usable form, but with no loss to any of its parts and without the use of fuel of any type. This period of experimentation started in the year 1958 and lasted for 2 ½ years.

Lester Hendershot first demonstrated a small device in the late 1920's. Stories and pictures were published in the New York Times and in other papers at that time. He reasoned that through his device he was tapping the earth's magnetic field and deriving electricity from it.

The author, because of his keen interest in magnetism and related subjects, checked into the Hendershot story and other stories which rumor described as having generated usable electricity by unorthodox methods. Although there were some frauds and perpetuators of wild tales, nevertheless findings showed him that most of these demonstrations appeared to provide their authenticity and lack of any fraud on the part of the conceiver; still interest and involvement by science in general was lacking even after they observed the demonstrations. This because there was no known theory by which power could be demonstrated without either the use of fuel or an exchange of energy from one form to another.

Curiosity and diligent pursuit had its reward to the author, and he located Lester Hendershot in the city of Cypress, California. Mr. Hendershot had for some 20 years been inactive in his research but in the past few years he had demonstrated, on a limited scale, a much larger device than in his early days.

However, when we first met, Mr. Hendershot was confined to a wheel chair due to an industrial accident and at that time had no operating device. The last one he had made was taken by an interested industrialist from New York and a California engineer for evaluation of its construction and parts.

This was the beginning of 2 ½ years of wonderful but frustrating research. Frustrating because it was difficult to find common ground upon which the many interested and involved persons could agree. This because of their diversified interests and opinions. This device was a new experience to each and no one knew the method or the reason for its successful operation.

Lester Hendershot wanted to leave to the world something of great value. Using his simple device to light conventional light bulbs, operate TV, radio, and small motors, he could not doubt its reality; but neither could he explain its power when operating or why so often it would not operate at all. Interested associates and advisers wanted to believe that here in this device was a multimillion dollar invention nearly ready for marketing.

As no device was available for the author to observe in operation to fulfill his great desire, one had to be constructed. Using instructions from Lester Hendershot, he painstakingly, without a model and with only limited specifications, constructed the first of five devices, which consisted of basket weave coils, electrolytic condensers, small transformers, a permanent magnet, 2 bell ringing coils and one hand wound electrolytic condenser.

After seeing his first inanimate device come to life under the influence of Lester Hendershot, the author knew beyond a doubt that here was in part the nature of the next great break-through in science; and that limits based on studies of exchange of energy and/or quantum mechanics did not indeed exist.

What did exist was the problem of how to get Lester Hendershot and associates to realize the magnitude of what was demonstrated and how to get cooperation of science, which was necessarily skeptical that anything of value could come from limited scientific background.

During 1960 two arranged demonstrations to top electronic engineering groups were canceled because of fear of revelation of an invention. However, in mid April 1961, Lester Hendershot finally agreed to go all out in revealing every detail of both construction and operation of his device in an environment including men of science and the equipment needed to evaluate in detail the nature of the power generated by the device, and how this was brought about. However, Lester Hendershot passed away very suddenly on April 26, 1961, thus bringing to a close that phase of this project.

The author had, and still has, in his possession the last device which he had constructed. However this device is only so much material without the influence of Lester Hendershot - whatever that may be - and the device does not operate.

There were several variations of the Hendershot device, and all of them operated. The device that the author made was a simple two-bank unit employing two sets of electrolytic condensers. The two negative banks were all hooked together in a common ground.

The positive side were each hooked to a unique arrangement of three basket weave coils within a single unit, which was 6" in diameter by 3" high.

Fitting closely to the inner circumference of this triple coil was a condenser which was rewound from an 80 mfd, 400 volt electrolytic condenser, but dried before winding on a metal ring. The final capacitance was not critical. Units operated anywhere from 0.006 to 40 mfd, but they were critical as to balance. Each side had to be within less than 2% in value to the other.

Two small transformers were also used in the basket weave coil circuit, but value was not critical. The device also employed a large permanent magnet opposing two bell ringing coils which in turn were wired to the two banks.

This arrangement appeared to act similar to a pacer, as the magnet acted as a cushion to the bell coil circuits when they became activated. There were variations in capacitance, in inductance and even in circuit wiring, which all proved that the mystery of operation did not depend on a certain, exact type of device.

Description of other devices by other individuals show a broad detail of mechanical construction, but all had two things in common:

1. they did generate electricity without the use of fuel or of loss to any of their parts, and
1. there was an operator whom used individualized methods to trigger the device into operation.

John W. Keely, who demonstrated such a device for many years, is described in The Book of Chas Fort. In personal notes, which were available in Los Angeles, he stated this concerning his personal work, "I had thought that I could bring to the world a new source of power, but now, at this late date, I find that there is a personal influence involved which I cannot overcome". This statement was made in reference to starting his devices.

In the early stages of experiments with the Hendershot device, it seemed at times that the easy way out was to deny that which was observed because it did not fit our accepted theories. This despite the fact that there was no fraud or attempt at fraud. However, it became increasingly difficult to deny something observed and the result was to pursue it further, questioning the lack of understanding rather than the reality of that observed and experienced.

After over a year of experimenting with Lester Hendershot, it became apparent that this device was better described as a living, mechanical body, caged or geared into a force outside of itself. Its operation paralleled the relation of a windmill to the wind. Its becoming a living thing in space depended on a factor similar to that of a doctor massaging a heart that had stopped, or in triggering this heart with a pacer.

This idea seemed at first too far-fetched to warrant further consideration, but became more acceptable after observing and evaluating a characteristic common to all units (devices) made by us and also reviewing records or statements concerning other devices and demonstrations in the past.

When a device, which was not in operation, was first stated by Lester Hendershot the home-made condenser, which seemed to act as antennas, would pick up voltage pressure slowly at first and then faster. Following this the main condensers would do likewise, followed by a near 60 cycle pulse, which could be heard as a loud hum on the magnet and coil circuit. This pulse would surge from one bank to the other. At the peak of surge into the condensers, an added surge of power was visible on the scope pattern. The voltage now across the load would be anywhere from 90 to 140 volts AC depending on the model used.

The nearly 60 cycle oscillation was common to all units. On one unit a slight unbalance of the home-made condenser was compensated for by squeezing a soft spot on one condenser. After Lester Hendershot had started the device by squeezing it, his hand tired, so he turned it over to the author. A firm squeeze again started the output and you may be assured that it was a thrill to hold this pulsing condenser. It was a felling of holding the pulse of the living universe manifesting itself in a machine, even as in a living body.

**Letter to "The Journal of Borderland Research"
from Edward O'Brian, Patent Attorney (Ret.)
Huntington Beach, California
March 1989**

A while ago you indicated in the Borderland Journal that you were working on a Hendershot publication. At the time I made a mental note to write you regarding my limited knowledge of the subject. Unfortunately I forgot about this until I noticed that your publication on this was now available. In spite of this I think it might be of interest for me to briefly outline what I know of the subject.

As you probably know Hendershot lived near here (Southern California) during the closing of his life. He became friendly with the publisher of the local newspaper. The latter happened to be a friend of my wife. He had printed our wedding announcements - for free - when we were all students in Iowa. At about the time he knew Hendershot, my wife ran the Linotype at the paper because of the sad state of the family finances. It is probable that she met Hendershot but she does not remember meeting him.

During this period before his death, Hendershot and the publisher became friendly. On a few occasions he indicated to me that he wanted me to meet Hendershot. Since I did not know who Hendershot was and he did not explain at the time, the matter of my meeting him did not become a priority matter with me. Also the publisher's priorities in earning a living did not include the matter of introducing Hendershot and myself.

After Hendershot had committed suicide, the publisher brought over to me a collection of photos he had taken of a Hendershot device which he had taken when he stored it - in operative condition - in his garage for a period of months when Hendershot was concerned about someone taking it if he had it in his possession. Unfortunately, the photos did not adequately disclose any technical details. It is equally unfortunate that he wanted and got them back. There is a vague chance that the publisher's widow might still have them.

The publisher told me that the device had operated continually while he had it. The illumination of the light connected to it apparently varied from time to time. I have a vague recollection of his telling me that Hendershot periodically would adjust the device when this happened.

This led to an associate and myself investigating the Hendershot device to a moderate extent. This investigation included a visit with Mr. Aho in the high desert part of Los Angeles County. He had a Hendershot device there which he said that Hendershot had started. I forgot why he said that it had once stopped operating. Apparently he had had quite a number of people trying.

This was the critical aspect of the matter. He showed me how Hendershot would "stroke" a wire along some part of the device until a meter started responding. Then apparently Hendershot would get excited as he continued the stroking motion until the meter would show that the device was in operation or was ready to go operational. At this point Hendershot would connect up the wire he had been using to stroke with.

Aho allowed me to sketch them both, the circuit he used and a key part of the device - a coil. He also said that there was another circuit which someone said was "The" Hendershot circuit and I made a record as to it. As I recall the sketch on the coil had dimensions, wire sizes, number of turns, etc. Aho stated that Hendershot indicated that Aho had done a better job on winding the coil than he, Hendershot had ever done.

From another source at the time I learned that Hendershot apparently got his idea as to his device from an earth-induction compass such as was used in the Spirit of St Louis airplane flown by Lindbergh. I have no idea if this is true or as to the construction of such a compass. *(See Appendix E).*

I should add that none of the materials I have on this have been discarded. However, I have not yet located them since closing my office.

Edward O'Brian, Patent Attorney (Ret.)

**THE FOLLOWING IS THE
LESTER J. HENDERSHOT STORY
AS TOLD BY
MARK M. HENDERSHOT
Publicly released in December 1995**

My name is Mark Hendershot, and Lester J. Hendershot was my Father.

Lester was an inventor and in his many attempts at producing practical items, he had a moderate success a few times with electronic toys, and had sold some of his ideas to small manufactures. His biggest idea, however, was so revolutionary that it embarrassed the nation's top scientists because they couldn't explain it, and if it could be perfected, it would possibly eliminate the need for public electric utilities in many instances, and it would completely change most of our present concepts of motivation.

His earlier invention was called a "motor" by the newspapers, but it was actually a generator which was powered by the magnetic field of the earth. His later models created enough electricity to simultaneously light a 120 volt light bulb and a table model radio. I witnessed it furnishing the power to run a television set and a sewing machine for hours at a time in our living room.

It was in 1927 and 1928 that my Father began to think seriously about this "fuelless" generator. He had taken up flying in 1925 and he soon realized that the ultimate development of aviation would be greatly enhanced by the creation of an absolutely true and reliable compass, and his first efforts were to producer such an instrument.

He theorized that the magnetic compass did not point to true north and varies from true north to a different extent at almost every point on the earth's surface. Also, the induction compass has to be set before each flight and at that time was not always reliable. He claimed that with a pre-magnetized core he could set up a magnetized field that would indicate the true north, but he did not know just how to utilize that in the compass he had set out to develop.

In continuing his experiments, he found that by cutting the same line of magnetic force north and south, he had an indicator of the true north. By cutting the magnetic field east and west, he could develop a rotary motion.

With this principle in mind, he switched his plans and began working on a motor which utilized this magnetic power. He built one that would rotate at a constant speed, a speed predetermined when the motor was built. It could be built for a desired speed, he said, and he felt that a reliable constant speed motor was one of the greatest needs in aviation at that time. The one built developed 1,800 revolutions per minute.

In the following years, he realized that the idea of a magnetically powered motor was not as practical as a magnetically powered generator, so his later work was directed towards the generator.

To avoid confusion, it should be pointed out that the early experiments began on a magnetically powered MOTOR, and later a GENERATOR.

The first significant experiments on the motor version were held at Selfridge Field, Detroit, under the direction of Major Thomas G. Lanphier, commandant of the field and leader of the First Pursuit Group.

The device demonstrated at Selfridge was a small model of what he hoped would be developed into an aeroplane engine. Quotes in the newspaper referred to top aeronautical brass of the day and their impressions of what they saw.

One such report was credited to William B. Stout, president of the Stout Air Service, Inc., designer of the all-metal type plane used by the Ford Motor Company. Stout's comments were, "The demonstration was very impressive. It was actually uncanny. I would like very much to see a large model, designed to develop enough power to lift an aeroplane."

Major Lanphier's comments to reporters after the demonstrations were, "The whole thing is so mysterious and startling that it has the appearance of being a fake."

"I was extremely sceptical when I saw the first model," he continued, "but I helped to build the second one and witnessed the winding of the magnet. I am sure there was nothing phoney about it."

My Father had first shown the military brass how his model worked, then he supervised army technicians in building their own model, which worked perfectly. Major Lanphier said that the electrical men to whom they had shown the motor..... laughed at the way we wired it up and said it wouldn't work. Then it DID work."

It was the Selfridge Field experiment which touched off the series of stories in the national press. Stories with blaring headlines in such papers as the Detroit Free Press, Detroit News, Detroit Times, Pittsburgh papers, the New York Times, and many others. Most of them tagged the instrument demonstrated at Selfridge the "miracle motor", and there were pictures of Major Lanphier and Col. Lindbergh, my Father and the motor.

Anything in the news during that period which could be connected with Lindbergh was front page whether he had an active interest, or just happened to be in the area at the time. Headlines in the various papers read, "*Gasless Motor Tested for Lindy*", "*Lindy Inspects Fuelless Motor For Aeroplanes*", and "*Lindbergh Tries Motor That The Earth Runs.*" One story even stated that, at its request, Lindbergh and Lanphier were flying to New York to show the motor to the Guggenheim Foundation for the Promotion of Aeronautics.

Later reports, however, emphasized that Lindbergh actually had nothing whatsoever to do with the experiments, and that he had just witnessed a couple of the demonstrations as the guest of his friend, Major Lanphier.

The Selfridge tests seemed to satisfy Lanphier and his associates, however, and during the period he was there, the model the technicians built obtained as high as 1,800 revolutions per minute and they announced its performance was entirely satisfactory. It was estimated these motors would run for 2,000 to 3,000 hours before the magnet center would have to be recharged.

A man named Dr. F.W. Hochstetter, of the Hochstetter Research Laboratories in Pittsburgh, hastily called a news conference and displayed models of what he said were the "Hendershot Motor". He demonstrated them, and when they would not work, he declared Hendershot was a fake, and that the motors worked only because of power derived from concealed pencil batteries.

After he had exhibited his models of the motor, Dr. Hochstetter announced that they would not generate enough electricity to... "light a 1 volt firefly" or to "stitch a fairy's britches."

Noting the lavish lecture room in a New York hotel which had been rented by (or for) Dr. Hochstetter for the press conference, Dr. Hochstetter was asked why he was SO interested in the Hendershot demonstrations and in trying to discredit them. He replied merely that he had "come to expose a fraud which would be capable of destroying faith in science for 1,000 years" and he claimed his only motive was that "pure science might shine forth untarnished."

It was obvious to those who were pro-Hendershot that, in view of all the fuss and bother of such a noted scientist as Dr. Hochstetter, somewhere behind it all, someone was anxious for the innovation to be ridiculed.

When approached with the accusations, my Father smiled and told reporters, "Dr. Hochstetter is correct, to a degree. I have concealed batteries in a model or two because I found that I could not trust some of my visitors, and I also had evidence that someone had tampered with my work. So I put a couple of batteries in on occasions to lead the intruders away from what I was working on."

He added that Major Lanphier and his army technicians were proof enough of his claims. "I didn't build the motor that was demonstrated at Detroit," he pointed out. "That was built by Army men under orders from Major Lanphier and under my direction. I didn't even so much as wind the motor. They built the motor and it works. That's my answer to all the critics - it works."

Dr. Hochstetter and his associates also claimed my Father had signed a contract and received \$25,000 for exploitation of the motor, but after a brief period of excitement, the matter was dropped - unproven.

Not long after his demonstrations of the motor, Dr. Hochstetter died under unusual circumstances. He was in a Baltimore and Ohio train wreck, and he was the only passenger on the whole train who lost his life!

My Father was the butt of many jokes and comments at the time of the debates about his invention. An artist, drawing for one of the Pittsburgh papers, depicted him in a cartoon riding a propellorless aeroplane. The caption made fun of him.

In later years my Father remarked, "Every time I see a jet plane go over now, I think of that cartoon and how everyone laughed at me for suggesting a plane could some day fly without a propeller. Twenty-five years ago I tried to tell them that."

As suddenly as it all started, the publicity and sensationalism of the Hendershot motor stopped. The last news story to appear was on March 10, 1928, when a small article appeared in most papers saying that Lester Hendershot was a patient in Emergency Hospital in Washington DC.

The personal account he gave was much the same as the newspaper quote, with the minor exception that he was hit by a bolt of 220 volts, not the jolting 2,000 the over-eager reporter had written. He was demonstrating the motor in the patent office, and the shock paralyzed his vocal chords, resulting in several weeks of recuperation before he completely recovered.

Something happened during this period that could explain the actions of Dr. Hochstetter and his associates. My Father said that while he was in the hospital, he was approached by a large corporation to stop his activity in connection with the motor or generator.

Until the day he died, he would not reveal the name of the company, only that if he were successful with his generator, it would be a serious threat to their multi-million dollar industry. He named the sum he accepted as \$25,000, and the condition was that he was not to build another unit for 20 years. That's when he dropped out of sight.

I have thought about the bizarre events connected with the generator, and feel it is possible the "large corporation first tried to stop the activities through Dr. Hochstetter. When this failed, they approached my Father personally and bought him off. It is interesting to note that one of the doctor's charges was that he was paid \$25,000 to exploit his work. Is it not odd that this is the same figure actually paid, but to STOP his activities, but was quoted BEFORE he was approached with the offer?

My Father admitted that he and the family lived in constant fear, as we were being contacted every so often by crackpots who had delved into the records and discovered his creation, and had gone to the trouble of searching him out. Some of them, he suspected, were representatives of subversive groups and/or foreign powers.

This latter charge seems a little exaggerated, but, was supported by a series of letters he received from a fellow in Ohio in 1952. He had traced my Father by going back to his hometown in Pennsylvania and talking to my uncle about the generator.

The first letter explained that he was a part of a group of scientists who were privately financing their own research on the same phenomena my Father discovered in 1928. He emphasized they would not allow backing by any organization or government since an invention such as the Hendershot Generator should be for "all the peoples and should not be controlled by national governments, but should be given gratis to the World Government when it is ready to assume World Responsibility." He was critical of my Father for allowing the military to look at it in 1928.

That letter was written in April 52, and in June a post card came with the following terse message, "Will shortly make public via radio and newspaper, connection your generator with 'Flying Saucer Propulsion'. Request Security Clearance from Security Chief you group within 48 hours. Have succeeded in duplication of your Generator."

In July 52 my Father received a four-page hand-written epistle from the Ohio man. To my knowledge, it was the last letter the writer sent on the subject. He discussed information his intelligence had received on flying saucers, modestly admitting his sources were better than the CIA or the FBI, which he claimed had investigated him several times. He intimated that the Pasadena scientist had recently been kidnapped because he was working on an attempt to adapt the generator to aircraft.

Then he went into a long and rambling dissertation on how he became interested in what he called the "Ether Vortex Phenomena" and the generator. He explained that the magnetic field in the earth and volcanic action are related, according to his studies. He had spent two and one half years in Japan working with Japanese volcanic scientists on the subject.

He mentioned one study he had made, and pointed out that the shift of the strata causing the volcanic eruption was due to a rotation of the ElectroMagnetic Field of the volcano at high speeds. He urged my Father to write a complete paper on his findings and publish them (preferably send them to the *Earthquake Research Institute* in Tokyo).

Referring to a particularly bad earthquake which had just occurred in the Los Angeles vicinity a few months before, the writer warned my Father not to operate his generator in the area near the San Andreas (seismic) Fault which runs through the area. He said, "You may not believe it, but YOU CAN CAUSE EARTHQUAKE ACTIVITY TO-INCREASE if you continue to operate your generator in that district. I am wondering if you were not directly responsible for the recent earthquake near Los Angeles?"

Then he promised that he and his associates would keep the possibility of his involvement in the earthquake to themselves.

Letters such as these, plus occasional phone calls when the callers would not identify themselves, and a threat from an admitted Communist which was turned over to the FBI, caused my Father concern much of the time. If a large organization would take over the generator and its research, all he wanted out of it was enough money to take care of himself and his family in the future years.

One of the most encouraging offers came in September of 1956 when my Father received word that officials of the Mexican government wanted to meet with him and discuss the possibility of using his generator for the rural development program in Mexico.

Government officials flew to Los Angeles and drove out to our house, where our family doctor who spoke Spanish acted as interpreter. Arrangements were made for the family to go to Mexico City, and for my Father to work with Mexican technicians on the generator.

We all flew to Mexico City and were housed in an apartment near the home of the Director of Electricity. My Father supervised the Mexicans in building a model. He had been working with them for several weeks, becoming more and more tense as time passed. He confessed to my Mother that he was frightened because he understood no Spanish, and his fellow workers talked constantly in little groups by themselves, often glancing over at him. He could not understand a word they were saying, and it worried him considerably.

One morning in February of 1957, the laboratory called and asked where my Father was. My Mother told them he had left for work in the morning, and if he was not there, she had no idea where he might be. She became increasingly concerned as the day passed and there was no word from him.

That night he did not come home, and we were on the verge of hysteria by next morning, then we received a telegram from Los Angeles. My Father's fear had worked itself into a nervous frenzy and he had rushed to the airport the day before and taken a plane for California. To the day of his death, it was a closed subject and he would never explain why he was compelled to leave us so suddenly under such strange circumstances, except that he feared for his life.

The final attempt to promote the generator came in the latter part of 1960 when a Dr. Lloyd E. Cannon convinced my Father that he had the facilities to present the project to the United States Navy for research and development.

Cannon said he was the General Manager of his own company, *Force Research* of Los Angeles, Palm Springs in the Mojave Desert. Cannon explained that his group was made up of many dedicated scientists of various fields who contributed time and knowledge to *Force Research* projects. The range of experimentation covered electronics, astronautics, free energies, propulsion, and para psychology.

Under my Father's supervision, two models were built and 100 copies of a 56-page "proposal" were printed for presentation to the various government agencies and politicians who would have to review the project for its consideration.

After the completion of the proposal and it had been sent to the government with no results, Cannon travelled the south-western United States with the models trying to raise money for research. His visits were increasingly less frequent to our home until 1961, when a tragic climax to this story occurred.

On April 19, 1961, upon returning home from school, I found my Father dead. It was recorded as a suicide without any further investigation.

For those who might be interested in my Father's analysis of how his generator worked, the following are his theories on the subject.

"The field of magnetism surrounding the earth is similar to the field of magnetism in a man-made generator."

"The rotor of a generator is revolved by some means of power, cutting the lines of magnetism, creating electric power. The earth is turning inside of a field of magnetism. That, no one contradicts, yet it is claimed there is no power to be derived from it."

"Let's say we have a mechanism that will collect, polarize and create a positive and negative connection to this tremendous power that is ever-present on the earth."

"Take a survey compass. You can hold the needle east or west, and let go of it, and it immediately goes north and south. This same power, when cut by the proper apparatus as the earth rotates inside this magnetism, will produce power, the amount of which is not calculated at this time."

"As long as the earth rotates around the sun, it will create electric power which some scientists claim does not exist. Yet, we dig into the mountains for material that costs us unbelievable sums, to create the same power."

"This magnetism surrounding the earth is in the same relation to electric power as uranium is to atomic power. Earth's magnetism is ever-present at any height or depth. It is equal to uranium as a by-product for power, namely electricity."

"Magnetism must be cut. The lines of force circling the earth are constant and if this force is broken up, and polarized, you have the equivalent of uranium broken up, which creates a heat and in turn creates power."

"Breaking up the forces of magnetism, polarizing them, thereby creating a resistance for power, is the same principal as atomic energy."

"Scientists claim it requires friction to generate electricity. I claim the earth rotating as it does, according to scientific theory, creates friction as a generator. The ever-present magnetism is the field, or stator."

"We have only to utilize this source of power to light every home, highway, bridges, aeroplane or any type of thing that cannot now be lighted because of inadequacy of present facilities."

"A very small unit composed of wire, a magnet, several especially designed coils, condensers, collector units, and a few other minor items, will cut this force. Another especially designed mechanism will polarize it, giving a positive and a negative connection to any resistance and the result is the generation of electricity."

There you have the theory of how to create electricity from the magnetic force of the earth, written by a man with only a high school education.

As years went by I have always wanted to continue with my Father's invention, but have worried myself about possibly running into the same problems my Father did.

I would not do my Father justice just to stop all work on it and now I am ready to fulfil his dream. Since childhood I have been fascinated by electricity and have spent over 26 years in the electrical trade. Of his three son's, I alone have pursued this fascination and have applied my knowledge and experience to carry on my Father's work.

A lot of information has surfaced over the years, much of which is either backwards or just wrong according to my Father's notes kept stored away by the family. I am currently working on the Hendershot Generator and hope to have it working soon for a presentation at the *Colorado Springs Tesla Symposium.(1995)*.

Signed - Mark M. Hendershot

1996 UPDATE

(Note: Mark uses a reverse coil identification to Skilling - See Figure 5.8)

Since first publishing "From The Archives of Lester J. Hendershot", some information has come to light that warrants this update letter and other additions to the original. In December 1995, I received my Father's original hand drawing of the electrical schematic for the generator! It diagrams a completely different way to wire the generator. The diagram included in the first printing of this information packet has been in circulation for quite a while. My father made few notes of his work but instead preferred to keep the information in his head. This insured that when "people" would snoop around they could not steal his secrets. The box found containing this drawing also contained a drawing of the "1928 Motor" which was very old and therefore difficult to reproduce. However, as there has been a lot of interest in the Hendershot Motor, I have included both the drawing and a newly found photo with this update. As I have received letters from all over the world, I hope this new information will bring together a lot of different minds working for a common cause.

Following this letter, there is an insert that shows a different way to wrap the large coils (alternating clockwise/counter clockwise). It has not yet been determined which method will work the best.

I want to pass along a few tips for constructing the coils. I have found that starting with a plastic template drilled out for the 57 1/8 inch holes really helps. When using the template, start by removing the sharp points off nails that will slide in the holes. Start the L3 lower winding with the nails pushed only half way up with the heads protruding through the bottom side. This will allow you to wind the wire on shorter pegs and you can slide them up and shape the coil as you go.

After you complete L3 and L2 coils, replace the nails with wooden pegs cut longer than needed (approximately 6 inches long). By putting the wooden peg on top of the nail point you can push the wooden peg through the winding while pulling the nail out. After you replace all the nails with wooden pegs, finish wrapping coil L1. If you break a peg you can still slide a new one in its place. When you have L1, L2 and L3 wrapped completely, push all the pegs up to the correct height of approximately 3/8 inch above the windings and break off the excess left protruding through the bottom of the template. Use a sharp wood chisel or knife to clean up the rough edges on the pegs. Apply some glue to the bottoms of the pegs to secure them.

To wrap coil L4 you need to wrap several turns of electrical tape around the middle of the outside of coil L3. Use 28 AWG solid magnet wire and place 14 completed turns in a counter clockwise direction starting at the bottom of the coil keeping them tight and flat. Cover coil L4 with electrical tape after it is completed. After verifying the windings, dip the coils in hot wax to seal and protect them. Clean excess wax off the coil leads after the wax has cooled. To melt the wax use a large can inside of a large pan. Once you have placed the wax in the can, pour water into the base pan sufficient to insulate it from direct heat but not enough to make the can float. Use moderate heat to warm the water and melt the wax.

When finished, screw the completed coils to the board and connect the wires to terminal strips. This will make it easier to try different wiring configurations.

Cut a 5 inch diameter stainless steel tube to 2 ¾ inches long. This will be used for wrapping the foil and paper for inside of the large coils.

Use a 5" or 6" tall oil capacitor and cut the can off of the outside to expose the internal foil. Cut the leads from the top of the capacitor and very carefully unwrap the foil leaving the connection tabs in place on the foil. Once the foils have been removed from the roll, lay them flat on a smooth wooden table. Using a razor knife and metal straight edge, trim the bottom edge of the foil to 2 ¾ inches wide. Cut one foil to 40 inches long (B) and the other to 40 3/8 inches ©. These foils will have one tab on each. Cut one more foil 2 ¾ inches wide and 91 ¼ inches long. Remove all tabs off this foil. Clean all three foils in detergent to remove the electrolyte oil from the surface. This can be done inside a coffee can using hot water and detergent. Then rinse with clean hot water and allow them to dry.

Cut one piece of heavy white kraft paper 3 inches wide and 7 inches long. Lay this piece down flat on a long table. Then center the shorter foils (B&C) on it with a ¾ inch gap between the tabs in the middle. Use a small piece of masking tape to hold the foil in place on the paper.

Cut a piece of thin kraft paper to 3 inches wide x 97 inches long and place on top of the two shorter foils. Use a small piece of masking tape on each end to hold it in place. Then centre the 91 ¼ inch foil on top of the thin paper and use two small pieces of tape to hold it in place.

To wrap the capacitors on the stainless steel tube, start by taping the heavy side of the paper to the side of the tube. Roll the stainless steel tube with the paper foil assembly attached keeping all foils flat and centered in the paper. Tape the end with masking tape to hold it in place. The tabs should read 0.0078 mfd. This reading is somewhat dependent on how tightly the foil and paper are wrapped around the stainless steel tube. If necessary, adjust the tension to achieve 0.0078 mfd. Once two hand-made capacitors are complete and at the same capacitance cover them with another wrap of paper and seal them with hot wax.

After the wax has cooled, center the capacitors in the middle of the large coils and pour wax slowly in between the coil and capacitor to hold them in place. Pour only a small amount of wax at one time or the wax on the coils will melt and leak through. Always allow the wax to cool completely before adding more! Also, again, verify the capacitors are at 0.0078mfd and verify the proper count on L1, L2, L3 and L4 coil windings before sealing them in wax.

These coils are the Hendershot Coils, it does take some time, patience, and care to make them neatly and with the same tolerance.

On my model, I used a magnet ordered from Edmund Scientific Company, International Ordering (609) 573-6263 or in the US (609) 573-6250. The 155 Lift Industrial Magnet "Alnico Horseshoe Type" Part Number M31,105, Catalogue Number 15N1 1995 at a cost of \$165.00 each.

My Father used two solenoid coils from an old telephone ringer attached to a flat 1/8 inch thick x 1 ¼ inch wide x 4 ½ inch long "iron bar". The iron cores in the solenoid coils were attached to this bar at the centre of each pole on the magnet. An adjustment screw was used to pull the bar with the solenoids attached away from the horseshoe magnet poles. This would allow him to tune the Hendershot Generator. It is extremely important that the bar stays at an equal distance from both the north and south poles when adjusting it.

There are two more transformers required for the project. They are 5:1 ratio vertical output transformers from old TV's. Other 5:1 ration power transformers should work but they will not have the colour coding on the input/output terminal wires, shown on the diagram.

The two duel 40-80 mfd electrolytic capacitors 400 volt non-polarized are hard to locate. You may have to use a substitute for them. It took me a long time to find mine in an outdated parts box at a used radio parts store! Be sure to test them to verify the accuracy of the capacitors.

Use terminal strips on all connections so you can change terminations for different wire patterns and testing of each component.

It is very important that all tolerances are close so that the unit will resonate properly and produce electricity.

The information provided here is everything that is presently available. I will continue my work on the generator, as well as continuing to compile and update the information as it becomes available. I hope these instructions will help you in the successful construction of the Hendershot Generator.

Good Luck!

Sincerely,

Signed: *Mark M. Hendershot*

NOTE: The details in this 1996 update relate to what I have called the Mark III Generator (of which there are a number of different circuit designs and some variations in components). Mark Hendershot named this Mk III design "Magnatronic Generator". To my knowledge, there is no public report that anyone, other than Lester Hendershot, has ever been successful in getting this device to work. Thanks to Mark's release of his father's original records that survived, it may now be possible to retrace his developments.

FIGURE C.1

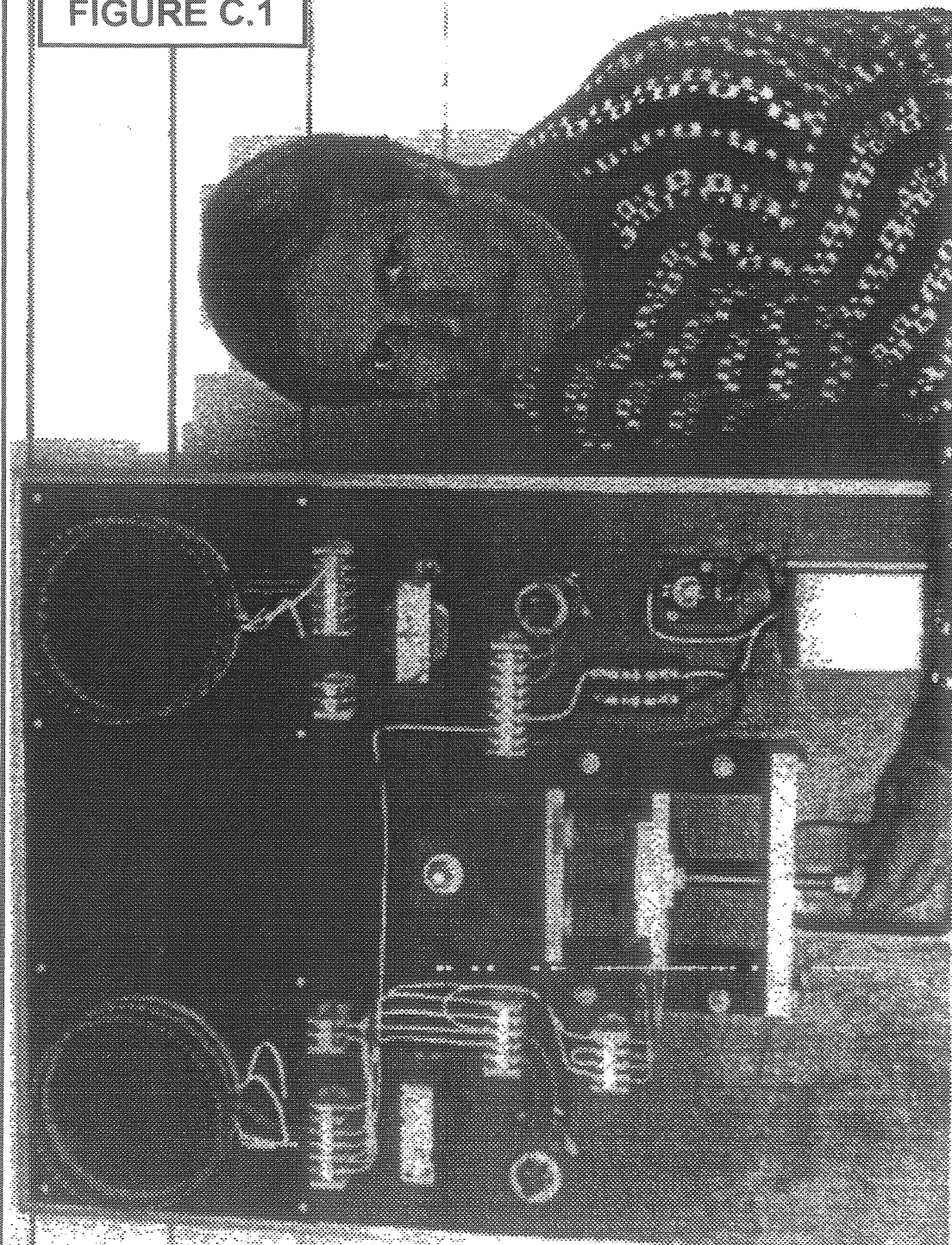

**Mark Hendershot with his version of
Lester Hendershot's Mark IIIB Generator**

THE HENDERSHOT PATENT DRAFT
Compiled from documents made public by
Mark M. Hendershot
(Son of Lester Hendershot)

The following is a covering letter for the Draft Patent Application that follows (Mark Hendershot indicates this letter came from Charles Lindbergh's Attorney at the time):

Attorney at Law-Patent Causes
Tele: Main 3008

Henry Orth Jr.
902 F Street N.W.
Washington, DC
Feb. 4, 1928

Dear Sir:-

I should like to know the following:

1. Can the aerial plate be vertical and can it be turned in any direction?
2. Can the aerial plate be vertical and pivoted so that the plate and extension can swing to and from the core 3.
3. Can coil 6 be arranged at right angles to the position shown?
4. Need core 7 pass through coil 6?
5. Are coils 13 and 14 provided with cores?
6. Coils 13 and 14 offer considerably resistance. Cannot a high resistance be used in place of these two coils and the resistance 17.
7. Can the plate 28 remain stationary?
8. Must the coil 4 be connected as shown or could it be connected so?

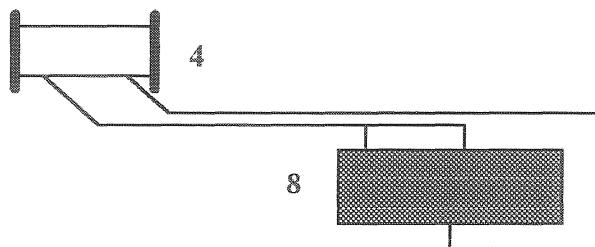

9. Must these coils 13 & 14 be so placed that one shall be on one side and the other on the other side of the longitudinal vertical central plane through the apparatus?
10. May fine wire coil 19 have a core connected to the transformer iron?
11. Can the transformer iron be omitted?
12. Must coil 4 extend only partly across coil 8?
13. Can coil 4 be shifted at an angle or at right angles to coil 6, or
14. Can the aggregate of coils 22-19 be placed parallel to coil 8?
15. Can the direction of winding of one of the fine wire coils be reversed.

There are important questions that come to mind and will be of great importance in determining the strength of the patent, and if you can possibly do so, answer these from your new experiments and number your answers to correspond to number of the questions.

I enclose preliminary draft of the description and claims and wish you would fill in the data as to the number of turns and sizes of wire for different coils. Return the description with such additions and corrections as you are able to make.

You will note that the draftsman has omitted the copper wire from the collector (1) extending along extension (2). I see no reason why this can not be done and he has probably done this under your instructions. If this cannot be done, I will have drawing corrected.

Claim 1, which is the broadest claim, must be stripped of all unnecessary parts, and I will ask you to give this point careful consideration.

If at the time you receive this letter you have had time to make additional tests or experiments, please come down here for a short conference.

Note: The modification by the draftsman mentioned above was probably not authorized by Hendershot. To connect wire (5) to the bottom of the resonator (2), would restrict its free oscillation - Hendershot's connection directly to the collector plate (1) would therefore be more appropriate.

Unfortunately the follow up or reply to this letter and patent, has never been made public knowledge (if there every was one).

Part 2

The following is the draft patent description of Mark I & II designs of his AC Generator's from 1927/28, and probably was attached to covering letter.

1. My invention relates to the production of electric current and has for its object to generate current for power & lighting purposes, and any other uses that it is desired to make of it.
2. Referring to the drawings, in which like parts are similarly designated, I used a small collector (1), preferably a small metallic plate horizontally disposed and having a downwardly extending flexible strip (2) of magnetic material terminating opposite a core (3) of a first coil (4) to be attached thereby. *[NOTE 1: By "attached thereby", I assume he means coil (4) is wound on core (3), and not that strip (2) is to be attached to either (3) or (4)].*
3. The strip (2) has soldered to it's lower end, a copper wire (5), which may extend to the collector proper (8), whose other end is soldered to the middle of the inner winding, or layer of a second coil (6).
7. The coil (6) is composed of X turns of No. X insulated copper wire, and is provided with a permanent magnetic core (7), and is preferably parallel to the first coil. *[NOTE 2; The first coil is most probably coil (4), - In this case coil (6) and its magnetic core (7) should lay horizontally in the centre of coil assembly (8). NOTE 3: On the other hand, the first coil may relate to coil (8), which in this case coil (6) and core (7) would be positioned vertically in the centre of coil assembly (8)].*
8. The core (7) and its windings (6) lay in the centre of a honeycomb coil (8) that has two windings (8A) & (8B), each composed of X turns of No. X wire, the windings being cross wound. *[NOTE 4: No mention is made of a core for windings (8) on the Mark I device, or the pitch and wavelength for the honeycomb cross windings around coil assembly (8) - Major Lanphier states in the NYT Feb 27, 1928, that the Mark II device had a permanent ring magnet around which the Honeycomb windings were wound with a diameter of approx. 3 inches, together with another set of coils passing through the centre of the ring. He also states that a larger model was made at Selfridge Field with an outside diameter of 7 inches and an inside diameter of 6 inches. See Appendix A].*
9. The ends of the winding (6) are connected to one terminal of each honeycomb winding (8A) & (8B) via connecting wires (9) & (10) respectively. The outer terminals of the honeycomb windings are then connected to the power lines via (11) & (12), respectively. *[NOTE 5: It is not stated if windings (8A) & (8B) are diametrically wound or wound in the same direction, nor is a specific direction given].*
10. The ends of coil (4) are respectively connected to two coils 13 and 14 wound in opposite directions, each consisting of X turns of No. X wire and provided with soft iron cores 15 and 16 respectively. The coils (4), (13) and (14) are connected in series in a preferably permanently closed circuit with a resistance (17) included between the coils (13) and (14), and in the structure that I have made, this resistance is small of about X Meg. Ohms.

11. The coils (13) & (14) are substantially parallel to the honeycomb coils (8), one on each side of the longitudinal vertical central plane of the apparatus. *[NOTE 6 : As an analogy: it may be visualized that if four players were lined up down the field in front of a goal to represent coils (4), (19), (22) & (25), then the goal posts would represent coils (13) & (14), and the goalie would represent coil assembly (8). But in this case the players and the goal are on different horizontal plains [See Drawing], and it is not certain if the goal posts are laying down or standing up].*

12. One end of the core (3) is soldered to one side of the square transformer plates (18), at its mid point, and forms a magnetic coupling between core (3) and plates (18).

13. Transformer plate sets (18) & (27) have openings in their centres for the reception of fine wire coils (19) & (25) respectively and with each composed of X turns of No. X wire. There is no core in either of the coils (19) and (25).

14. The inner end of coil (19) is connected to power line (11) via wire (20), and the outer end of coil (19) is connected by wire (21) to the inner terminal of the third coil (22) with X turns of No. X wire. Like with core (3) in Statement 12 above, core (23) is metallicly connected to transformer plates (18) on the opposite side to core (3). The core (23) may be omitted. *[NOTE 7: Why this last sentence is included is unclear, seeing as he has clearly specified its inclusion in the magnetic circuit].*

15. The outer end of coil (22) is connected to the inner terminal of coil (25) via wire (24), with the outer terminal of coil (25) connected to the power line (12), via wire (26). The windings of coils (19) & (25) are in a diametric relationship across coil (22).

16. Coils (19) & (25) are identical and are respectively placed inside the outer square transformer laminations of (18) & (27) at 90 degrees to the outer frames. The four coil assemblies are then arranged in a line as shown in the diagram with an air gap between transformer edge (27) and core (23) so that there is no metallic coupling between the two. The coils (19) and (25) are also arranged so that the direction of their windings are opposite as indicated by the arrows in the drawing. *If the assembly is viewed from the resonator end, coils (4) and (22) are both wound in either a clockwise or an anti-clockwise direction - The direction of the arrow on the drawing is hard to interpret..*

17. It will be noted in the construction shown that coil assembly (4) extends across half the face of coil assembly (8) and across coil assembly (6). The end of core (3) facing the resonator, is located vertically above the centre of coil assembly (8), with both assemblies (4) and (8) set at 90 degrees of each other. *[NOTE 8: The permanent magnet (7) of coil assembly (6) is probably parallel to and arranged in the same vertical plain as core (3) of coil assembly (4). There is no mention of which way the poles of the permanent magnet should face].*

18. The axis of coils (13) and (14) are parallel to the honeycomb coil assembly (8). *[NOTE 9: By this statement I assume he means that coils (13) and (14) are in the same horizontal plane as coils assembly (8), but it is still unclear if (13) & (14) should face vertically up or in the same direction as coil assembly (4)]. If this means the axis of (13) & (14) are parallel to axis (8), then axis (13) & (14) are vertically up.*

19. The coil assembly (6) is positioned within the coil assembly (8) and the axis of coil assembly (4). *[Note 10: From this it may be assumed (6) and (4) are in the same vertical plane, and face the same way (parallel axis's) and is positioned one above the other (at least half of (6)].*

THE MARK II MODIFICATIONS

20. A lamp or small motor connected across the ends of the power lines or terminals (11) and (12) will operate continuously when the longitudinal axis of device is directed north and south, and will cease to produce power when deviated from the north & south direction. That is to say, the motor will stop or the lamp will cease to glow. To overcome this objection for some purposes, and in order to permit the structure to operate in any direction which its axis is placed, I have modified the structure of coil assembly (8) and parts within it; all other parts - remaining same.

21. The extension (2) of plate antenna (1), is connected by wire (5) to a small pivoted soft iron plate (28) within a short coil (29) with X turns of No. X wire, between brass end plates (30), and is held in a soft iron yoke (31) by a screw (32) that passes through one pole end of a ring magnet (33). The screw (32) serves to hold the yoke (31) to the magnet pole end and at the same time holds the coil (29) in the yoke (31). The plate (28) is pivoted in one of the brass end plates (30).

22. The coil (8A) is a single wire cross wound coil having, one turn of No. X wire. One end of this coil (8A) is connected by wire (9) to one end of the coil (29), and the other end (8A) to the line wire (11). Surrounding this coil (8A) is a second coil (8B) of the same size wire and the same number of turns. The other end of coil 29 is connected by wire (10) to one end of the second and outer honeycomb coil (8B) whose other end is connect to the other power line terminal (12).

23. It will be noted the coil (4) extends across one side of the coils (8A) & (8B) and also across the coil (29). *[NOTE 11: This is the same layout as Mark I indicated in section 17 above.]*

24. That coil (29) is positioned within coil assembly (8) and the axis of coils 4 & 29. *[NOTE 12: This is probably supposed to read "That coil (29) is positioned within coil assembly (8) and the axis of coils 4 & 29 are in the same vertical plane ,and face in the same direction (axis of (4) & (29) parallel)].*

25. That coils 6 and 29 must be substantially parallel. *[NOTE 13: I think this is supposed to mean that coil 6 in the Mark I design and coil (29) in the Mark II design are identically positioned and located. Clearly coil (29) is a substitute for coil (6) in the first design, and therefore cannot exist in the same circuit together].*

PART 3**HENDERSHOTS DRAFT PATENT CLAIMS**

CLAIM 1. I claim in an electrical apparatus, a collector (1), a coil (4) having a core (3) one end of which is in attracting relation to a portion (2) of said collector (1), a honeycomb coil (6) each end of which is connected to one of the windings of the honeycomb (8A)&(8B), means to send electricity from the collector(1&2) to said second coil (6) via (5), a pair of oppositely wound coils (13)&(14) parallel to the honeycomb coil (8) and constructed in series with the first coil (4), a fine wire coil (19), transformer iron (18), surrounding fine wire coil (19), a third coil (22), a second fine wire coil (25), transformer iron (27) surrounding the same (25), said third coil (22) and fine wire coils (19)&(25) connected in series across the line (11)&(12). *This claim does not mention the magnet core (7), the resistor (17) nor does it mention the metal connections between (3,18 & 23) - Mark I only.*

CLAIM 2. In an electrical apparatus, a collector (1) having an extension (2), a coil (4) having a core (3) one end of which is in attracting relation to said extension (2), a honeycomb coil (8) having two windings (8A&8B) perpendicular to the coil (4) and its one end (of 8A & 8B) connected to lower terminals (11)&(12), a second coil (6) within the honeycomb coil (8), each end of which (6) is connected to the opposite end of one of the honeycomb windings (8A&B), a permanent magnet (7) is or is in inductive relation to said second coil (6), means to send current (5) from the collector(1&2) to the second coil (6), a pair of oppositely wound coils (13&14), said first coil (4) connected in series between said pair of oppositely wound coils (13&14), a fine wire coil (19), transformer iron (18) surrounding said coil (19) leaving a continuation that forms the core (3) of the first coil (4), a third coil (22) between which and the first coil (4) said transformer iron (18), and fine wire coil (19) is arranged, a second fine wire coil (25) wound in an opposite direction to the first fine wire coil (19), transformer iron (27) surrounding the second fine wire coil (25), solid fine wire coils (19&25) being connected in series through the third coil (22) across the power terminals (11&12), and the fine wire coils (19&25) arranged in rectangular relation to the first (4) and third (22) coils., *This claim does not mention the resistor (17).*

CLAIM 3. In an electrical apparatus, a collector (1), a coil (4) having a core (3) one end of which is in attracting relation to a portion (2) of said collector (1), a honeycomb coil (8) having two windings (8A&8B) connected to power terminals (11&12), a second coil (6) in the honeycomb coil (8A&8B) each end of which is connected to one of the winds of the honeycomb coil (6), means to send electricity (5) from the collector (1&2) to the second coil (6), a pair of oppositely wound coils (13&14) parallel to the honeycomb coil (8) and connected in series with the first coil (4), a resistance (17) between said oppositely wound coils (13&14), a fine wire coil (19), transformer iron (18) surrounding the fine wire coil (19), a third coil (22), a second fine wire coil (25), transformer iron (27) surrounding the same (25), said third coil (22) and fine wire coils (19&25) connected in series across the line (11&12). *This claim makes no mention of the magnet (7) nor of the metal connections between (3,18 & 23), but it does include the resistor (17) - Mark I.*

CLAIM 4. In an electrical apparatus, a collector (1), a coil (4) having a core (3) one end of which, is in attracting relation to a portion (2) of collector (1), a honeycomb coil (8) having two windings (8A&8B) each connected at one end to power terminals (11&12), a second coil (6) in the honeycomb (8) traverse thereto and parallel to the first coil (4) and connected to the other ends of the honeycomb windings(8A&B), a permanent magnet (7) in inductive relation to said second coil (6), means to send current from the collector(1&2) to said second coil(6) (via 5), a pair of oppositely wound coils(13&14) parallel to the honeycomb coil (8), a resistance (17) included in series in a closed circuit between the ends of the first coil (4), a fine wire coil (19), laminated transformer iron (18) surrounding said fine wire coil (19) but not passing there through and having an extension (3) that forms the core of the first coil (4), a third coil (22) between which and the first coil (4) said transformer iron (18) and fine wire coil (19) is arranged, the first (4) and third (22) coils being wound in the same direction, a second fine wire coil (25) wound in opposite direction to the first fine wire coil (19) laminated transformer iron (27) surrounding the second fine wire coil (25) but not passing there through, said coil (22) is connected between the two fine wire coils(19&25) in series across the power terminals (11&12). *This claim makes mention of the metal connection between (18&4) but does not clearly specify a metal connection between (18&23). It also does not mention the gap between 23 and 27, although it does not say they are connected. This claim gives the only clear reference to the orientation and position of coil (6) and its core (7), it is also the first time that a reference has been made to the unidirectional windings of coils (4&22), but their direction has not been stated. - Mark 1*

CLAIM 5. In an electrical apparatus, a collector (1), a coil (4) having a core (3) one end of which is in an attracting relation to a portion (2) of said collector (1), a honeycomb coil (8) having two windings (8A&8B), each connected to a power terminal (11&12), a ring magnet (33) in the honeycomb coil (8), a second coil (29) in the magnet (33) and connected in series between the windings of the honeycomb coil (8A&8B), a pivoted oscillation member (28) within the second coil (29), means to conductively connect said collector (1&2 via 5) and member (28), a pair of oppositely wound coils (13&14) adjacent to the honeycomb coil (8) and connected in series with said first coil (4), a fine wire coil (19), transformer iron (18) surrounding the fine wire coil (19), a third coil (22), a second fine wire coil (25), transformer iron (27) surrounding the last coil (25), said third coil (22) and fine wire coils (19&25) connected in series across the power terminals (11&12). *This is the first version of the Mark II design which does not incorporate a soft iron yoke. From the description, the ring magnet may be the former for the honeycomb coils (8A&8B), but it is more probable that the ring magnet is a substitute for magnet (7) in the Mk 1 design. If this is the case, then the ring magnet would be a separate unit to coils (8) and lay at right angles to coils (8), much the same as coil (6) & core (7) in Mk 1. There are three possible orientations for the magnetic flux: (A) The cylinder (33) may be magnetized around its circumference - In this case no poles would be evident: (B) The cylinder (33) may be magnetized across its diameter. This is a possibility: (C) Lastly, The cylinder (33) may be magnetized like a solenoid coil with its poles at either end of the cylinder opening. -This is the most probable solution, as the ring magnet (33) is a substitute for core (7), and its magnetic orientation would probably be the same as in the Mark 1 version. It is clear that coil (29) is a substitute for coil (6) and is most probably identical in all respects (but with a magnetic yoke outside (33) and a resonator core (28) inside). The Resonator (28) is a free moving core of coil (29) and is anchored at one end to the centre of brass plate (30). This resonator (28) is a partial replacement for the centre core(7) of coil (6) in the Mark 1 version.*

CLAIM 6. In an electrical apparatus, a collector (1), a coil (4) having a core (3) in attracting relation to said collector (2), a honeycomb coil (8) having two windings (8A&8B) each connected to a power terminal (11&12), a ring magnet (33) in the honeycomb coil (8), a second coil (29) in the magnet (33) whose axis is at right angles to the axis of the honeycomb coil (8), a pivoted oscillating member (28) within the second coil (29), means to conductively connect the collector(1&2 via 5) and member (28), a pair of oppositely wound coils (13&14) adjacent the honeycomb coils (8A&8B) parallel thereto and connected in series with the first coil (4), a fine wire coil (19), transformer iron (18) surrounding the fine wire coil (19), a third coil (22), a second fine wire coil (25), transformer iron (27) surrounding the last coil (25), said third coil (22) connected in series between the fine wire coils (19&25) across the power terminals (11&12).

Claim 6 is almost identical to Claim 5 but worded slightly differently - The important information in Claim 6 is the defined orientation of Magnet (33), Coil (29) & its oscillatory core (28) being the same as Coil (6) and core (7) in the Mark 1 version.

CLAIM 7. In an electrical apparatus, a collector (1) substantially horizontally disposed and having a substantially vertical extension (2), a coil (4) having a core (3) in attracting relation to said extension (2), a honeycomb coil (8) having two cross wound windings (8A&8B) each of which is connected at one end to power terminals (11&12), a ring magnet (33) within the honeycomb coil (8), a yoke shaped extension (31) connected to one of the ends of said magnet (33), a second coil (29) held in said extension (31) parallel to the first coil (4), a soft iron member (28) pivoted in the second coil (29), means to electrically connect said extension (31) and member (28) while permitting independent movements thereof (28), a fine wire coil (19), laminated transformer iron (18) surrounding the fine wire coil (19) and having an extension (3) that form the core of the first coil (4), the third coil (22) arranged at right angles to the first coil (4), a second fine wire coil (25) wound in a direction opposite to the winding of the first fine wire coil (19) and parallel thereto (25), laminated transformer (27) surrounding the last coil (25), said third coil (22) arranged between the fine wire coils (19&25) in series and the series connected across the line terminals (11&12). *This claim includes the soft iron yoke (31) around the coil (29) with the ring magnet (33) moved horizontally to the end of the iron core (31). This arrangement probably describes one of the devices demonstrated at Selfridge Field in February of 1928. It includes all the modified parts of the Mark 1 device and is claimed to operate in all directions or device orientations. The last underlined statement states, that "coil (22) and coil (4) are at right angles to each other": This statement does not correspond to the drawing, nor any of the other claims or descriptions given - It may therefore be a mistake or a variation of the other designs.*

The following is the original patent draft February 1928

My invention relates to the production of electric current, & has for its object to generate current for power & lighting purposes., & any other uses that it is desired to make of it.

Referring to the drawings, in which like parts are similarly designated:

Fig. 1 is the diagrammatic view of one construction.

Fig. 2 is similar view of another construction.

Referring to Fig. 1: I use a small collector 1, preferably a small metallic plate horizontally disposed and having a downwardly extending flexible strip 2 of magnetic material terminating opposite a core 3 of a first coil to be attached thereby. The strip 2 has soldered to it one end of a copper wire 5, which may or may not extend to the collector proper 8, whose other end is soldered to the middle of the inner winding or layer of a second coil 6. This coil is composed of turns of no. insulated copper wire, & is provided with a permanently magnetic core 7, and is preferably parallel to the first coil. The core 7 and its windings 6 lie in the center of a honeycomb coil 8 that has two windings, each composed of turns of no. wire, the windings being cross wound. The ends of the winding 6 are each connected by connecting wires 9 & 10 respectively, to an end of one of the crossed windings of the honey-comb coil 8 and the other ends of the windings are then connected to the power lines or terminals 11 & 12 respectively. The ends of the first coil 4 are respectively connected to two coils 13 & 14 wound in opposite directions, each consisting of turns of no. wire & provided with soft iron cores 15 & 16 respectively. The coils 4, 13 & 14 are connected in series in a preferably permanently closed circuit with a resistance 17 included between the coils 13 & 14, and in the structure that I have made, this resistance is small of about Meg. Ohms. The coils 13 & 14 are substantially parallel to the honey-comb coil, one on each side of the longitudinal vertical central plane of the apparatus. The core 3 is soldered to a set of small transformer plates 18 & forms an extension of these plates. These plates have openings in their center for the reception of a fine wire coil 19, composed of turns of no. wire. There is no core through coil 19. The inner end of coil 19 is connected to one line terminal 11 at 20, and the outer end is connected by wire 21 to the third coil 22 of turns of no. wire, whose core 23 has metallic connection with the transformer plates 18. The core 23 may be omitted. The end of the outer turn of coil 22 is connected by wire 24 to the inner turn of a second fine wire coil 25 like coil 19 but wound in the opposite direction, and the outer end of this coil is connected at 26 to the other power line terminal 12. The fine wire coil 25 is placed in the interior of laminated transformer plates 27, identical with the plates 18 and the coil has preferably no metallic core, and the transformer plates 27 are separate from those 18. The direction of the winding of the coils is indicated by arrows. A lamp or small motor connected across the ends of the power lines or terminals 11 & 12 will operate continuously when the longitudinal axis of the device is directed north and south, and will cease to produce power when deviated from the north & south direction. That is to say, the motor will stop or the lamp will cease to glow. To overcome this objection for some purposes, and in order to permit the structure to operate in any direction in which its axis is placed, I have modified the structure of coil 8 and the parts within it; all other parts remaining same. The extension 2 of plate 1 is connected by wire 5 to a small pivoted soft iron plate 28 within a short coil 29 of turns of no. wire, between brass end plates 30, and is held in a soft iron yoke 31 by a screw 32 that passes through one pole end of a ring magnet 33. The screw 32 serves to hold the yoke 31 to the magnet pole end and at the same time holds the coil 29 in the yoke 31. The plate 28 is pivoted in one of the brass end plates 30. The coil 8a is a single wire cross wound coil having turns of No. wire. One end of this coil is connected by wire 9 to one end of the coil 29, and the other end to the line wire 11. Surrounding this coil 8a is a second coil 8b of the same

2.

size wire and the same No. of turns. The other end of coil 29 is connected by wire 10 to one end of the second and outer honey-comb coil 8b whose other end is connected to the other power line terminal 12. It will be noted that in both constructions shown the coil 4 extends across one side of the coil 3 or the two coils 8a & 8b and also across the coil 6 or 29. That coils 6 & 29 lie within the coils 8 or the 8a & 8b, and the axis of coils 4 & 29 as well as coils 4 & 6 must be substantially parallel. Also the axis of coils 13 & 14 are substantially parallel to the honey-comb coils 8, 8a and 8b. I claim-
1. In an electrical apparatus, a collector, a coil having a borey-one end of which is in attracting relation to a portion of said collector, a honey-comb coil having two windings connected to power terminals, a second coil in the honey-comb coil each end of which is connected to one of the windings of the honey-comb means to send electricity from the collector to said second coil, a pair of oppositely wound coils parallel to the honey-comb coil & connected in series with the first coil, a fine wire coil, transformer iron, surrounding the fine wire coil, a third coil, a second fine wire coil, transformer iron surrounding the same, said third coil & fine wire coils connected in series across the line.

2. In an electrical apparatus, a collector having an extension, a coil having a core one end of which is in attracting relation to said extension, a honey-comb coil having two windings perpendicular to the coil & its one end connected to power terminals, a second coil within the honey-comb coil, each end of which is connected to the opposite end of one of the honey-comb windings, a permanent magnet is or in inductive relation to said second coil, means to send current from the collector to the second coil, a pair of oppositely wound coils, said first coil connected in series between said pair of oppositely wound coils, a fine wire coil, transformer iron surrounding said coil having a continuation that forms the core of the first coil, a third coil between which and the first coil said transformer iron, and fine wire coil is arranged a second fine wire coil wound in an opposite direction to the first fine wire coil, transformer iron surrounding the second fine wire coil, said fine wire coils being connected in series through the third coil & across the power terminals, and the fine wire coils arranged in rectangular relation to the first & third coils.

3. In an electrical apparatus, a collector, a coil having a core one end of which is in attracting relation to a portion of said collector, a honey-comb coil having two windings connected to power terminals, a second coil in the honey-comb coil each end of which is connected to one of the windings of the honey-comb coil, means to send electricity from the collector to the second coil, a pair of oppositely wound coils parallel to the honey-comb coil & connected in series with the first coil, a resistance between said oppositely wound coils, a fine wire coil, transformer iron surrounding the fine wire coil, a third coil, a second fine wire coil, transformer iron surrounding the same, said third coil & fine wire coils connected in series across the line.

4. In an electrical apparatus, a collector, a coil having a core one end of which is in attracting relation to a portion of said collector, a honey-comb coil having two windings each connected at one end to power terminals, a second coil in the honey-comb, traverse thereto and parallel to the first coil & connected to the other ends of the honey-comb windings, a permanent magnet in inductive relation to said second coil means to send current from the collector to said second coil, a pair of oppositely wound coils parallel to the honey-comb coil, a resistance between the oppositely wound coils, said coils and resistance included in series in a closed circuit between the ends of the first coil, a fine wire coil, laminated transformer iron surrounding said fine wire coil but not passing there through and having an extension that forms the core of the first coil, a third coil between which and the first coil said transformer iron and fine wire coil is arranged, the first & third coils being wound in the same direction, a second fine wire coil wound in opposite direction to the first fine wire coil, laminated transformer iron surrounding the second fine wire coil but not passing there through, said third coil connected between the two fine wire coils in series across the

- power terminals.
5. In an electrical apparatus, a collector, a coil having a core one end of which is in attracting relation to a portion of said collector, a honey-comb coil having two windings each connected to a power terminal, a ring magnet in the honey-comb coil, a second coil in the magnet and connected in series between the windings of the honey-comb coil, a pivoted oscillating member within the second coil, means to conductively connect said collector and member, a pair of oppositely wound coils adjacent the honey-comb coil & connected in series with said first coil, a fine wire coil, transformer iron surrounding the fine wire coil, a third coil, a second fine wire coil, transformer iron surrounding the last coil, said third coil & fine wire coils connected in series across the power terminals.
6. In an electrical apparatus, a collector, a coil having a core in attracting relation to said collector, a honey-comb coil having two windings each connected to a power terminal, a ring magnet in the honey-comb coil, a second coil in the magnet whose axis is at right angles to the axis of the honey-comb coil, a pivoted oscillating member within the second coil, means to conductively connect the collector and member, a pair of oppositely wound coils adjacent the honey-comb coils parallel thereto & connected in series with the first coil, a fine wire coil, transformer iron surrounding the fine wire coil, a third coil, a second fine wire coil, transformer iron surrounding the last coil, said third coil connected in series between the fine wire coils across the power terminals.
7. In an electrical apparatus, a collector substantially horizontally disposed and having a substantially vertical extension, a coil having a core in attracting relation to said extension, a honey-comb coil having two cross wound windings each of which is connected at one end to power terminals, a ring magnet within the honey-comb coil, a yoke shaped extension connected to one of the ends of said magnet, a second coil held in said extension parallel to the first coil, a soft iron member pivoted in the second coil, means to electrically connect said extension and member while permitting independent movements thereof, a fine wire coil, laminated transformer iron surrounding the fine wire coil and having an extension that forms the core of the first coil, the third coil arranged at right angles to the first coil, a second fine wire coil wound in a direction opposite to the winding of the first fine wire coil & parallel thereto, laminated transformer iron surrounding the last coil, said third coil arranged between the fine wire coils in series and the series connected across the line terminals.

Attorney at Law-Patent Causes
Tele. Main 3008

Henry Orth Jr.
902 F Street N.W.
Washington, D. C.
Feb. 4, 1928

Principle of the Earth Inductor Compass

The ordinary mariner's compass is unreliable in aircraft because of the non-horizontal characteristics of manoeuvrability, vibration and other associated magnetic compass deflecting influences. To overcome such errors, specially designed airplane compasses have magnetic directional units stabilized against the motion of the craft. These units are called Gyrostabilized Magnetic Flux Gate Compasses. The predecessor of the modern aviation compass, was called the Earth Inductor Compass, and was used by early aviators such as Charles Lindbergh, in his famous transatlantic flight in May of 1927.

In the mid 1920's, Hendershot had learned about this type of compass when he took flying lessons at the local airfield. It was the technical problems associated with the use of this early type of compass, that probably inspired the young Hendershot to try and find a way to improve it. It was in the course of his experiments, that he discovered certain phenomena that led him to the development of his "Fuelless Electric Motor" and the "Solid-state Power Generator".

The "Fluxgate" phenomenon is created by the effect of an external magnetic field when passing through a circular toroidal magnet. If such a magnet is placed in a magnetically insulated container, it is normally assumed that the circulating magnetic flux strength will be identical through every cross sectional area of the circumambient ring. If however, the magnetic ring is removed from the container and placed horizontally in the plane of the earth's magnetic field, then the field contained within the ring magnet will no longer be uniform, but will display a constant magnetic differential diametrically across the ring in the east/west direction. This effect is demonstrated in the accompanying drawing in Figure E.1. The earth's magnetic lines of force travelling from left to right will reinforce and enhance the flux of the magnet on the top of the ring, whilst the field direction on the bottom of the ring will be diminished by the interacting opposing forces of the earth's field and the magnetic flow within the ring.

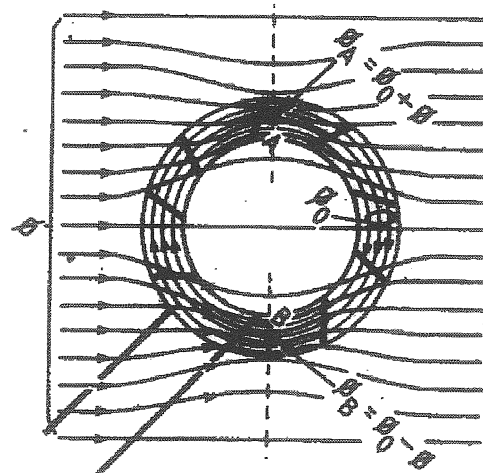
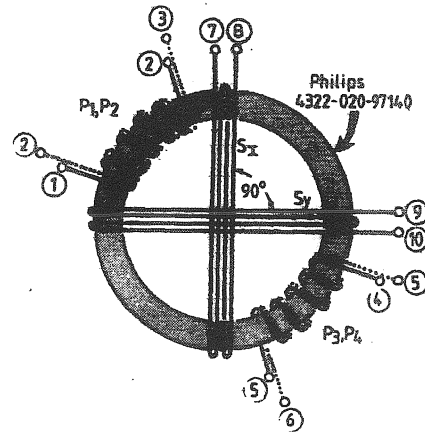

FIGURE E.1

It is probably this phenomenon that Hendershot used to activate his device. And by a cleverly arranged inductive circuit combined with a suitable feedback system, he has been able to amplify the output to produce useable power.

In a modern fluxgate magnetometer used for directional navigation, coils of wire are wound around a soft ferrite or Mumetal ring, as illustrated in Figure E.2. Primary drive windings are provided by P_1 and P_2 which are bifilar wound. A feed back line is provided by windings P_3 and P_4 which are also bifilar wound and serve to maintain oscillation of the primaries via an inverter circuit as shown in Figure E.3. The output is effected by two perpendicular secondary windings S_x and S_y which serve to provide a coordinate inductive grid reference when the toroid changes its horizontal rotational position.



P_1, P_2 - 2x50 turns 30 S.w.g. enamelled cu. wire
 P_3, P_4 - 2x10 " 30 " " " "
 S_x, S_y - 100 " 40 " " " "

FIGURE E.2

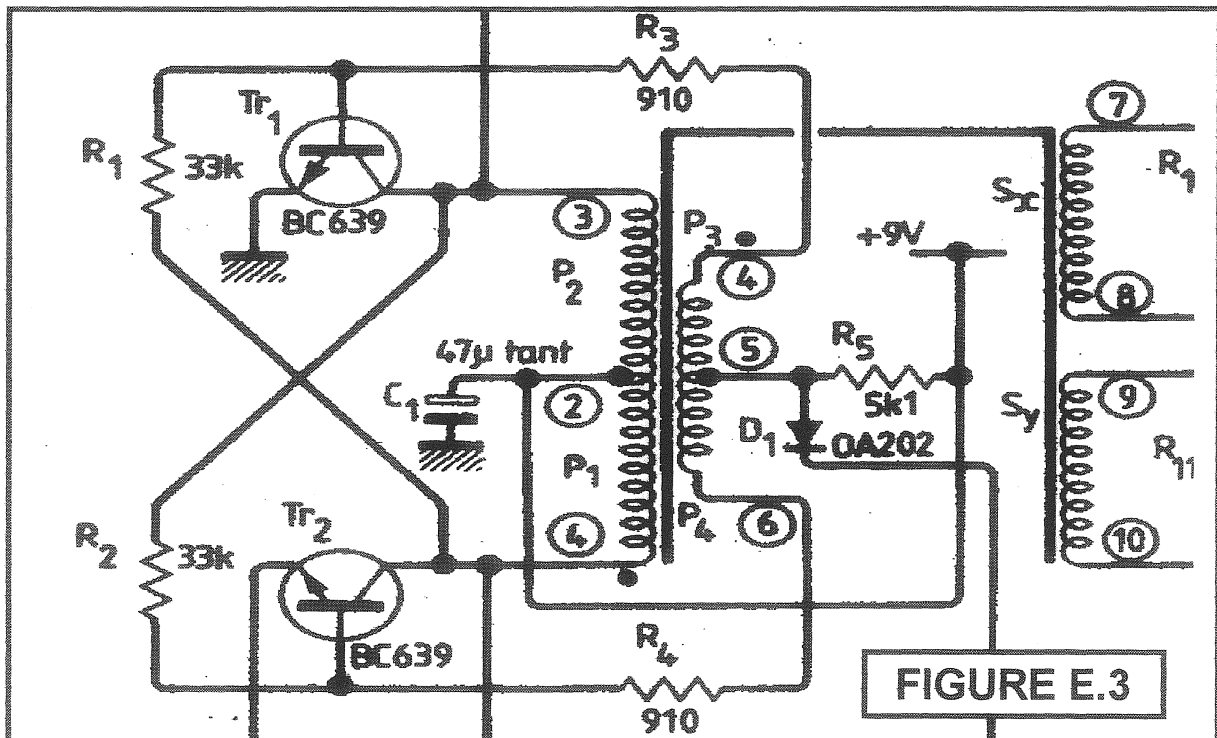

FIGURE E.3

When an external field is applied in the plane of the toroid some initial magnetization is induced in it. This initial magnetization results in one part of the toroid being driven into saturation before the part 180° away from it during one half of the oscillator cycle and the reverse situation occurring during the other half cycle. This non-symmetrical saturation of the core produces a flux unbalance and an induced voltage in the secondary windings. The magnitude of this induced voltage is closely proportional to the applied flux component perpendicular to the plane of the appropriate secondary coil. This phenomenon is so sensitive to closely related ferrous material not included as part of the design, that even a metal buckle worn by the operator or the use of transistors with metal jackets were sufficient to disturb the output of the device. Circuit wiring must also be as short as possible to avoid other unwanted interference.

For those who may wish to pursue Fluxgate phenomena further, the following references may prove invaluable:

W. F. Stuart, Earth's Field Magnetometry. Reports on Progress in Physics, Vol. 35, 1972, pp 803-881.

A. Hine, Magnetic Compasses and Magnetometers. Adam Hilger Ltd. London, 1968.

Should the reader wish to investigate the induction compasses used in early aviation, a visit to the patent office could be a worthwhile pursuit.
